

BRUEL & KJAER

A Guide to Mechanical Impedance and Structural Response Techniques

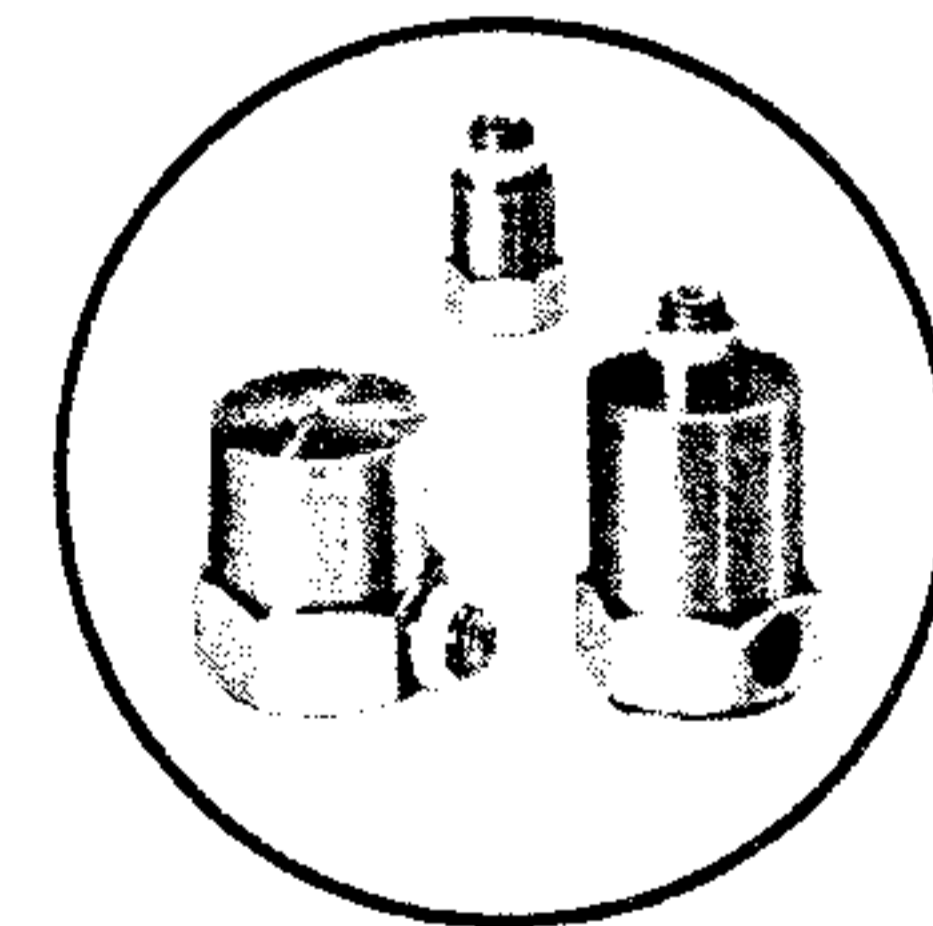
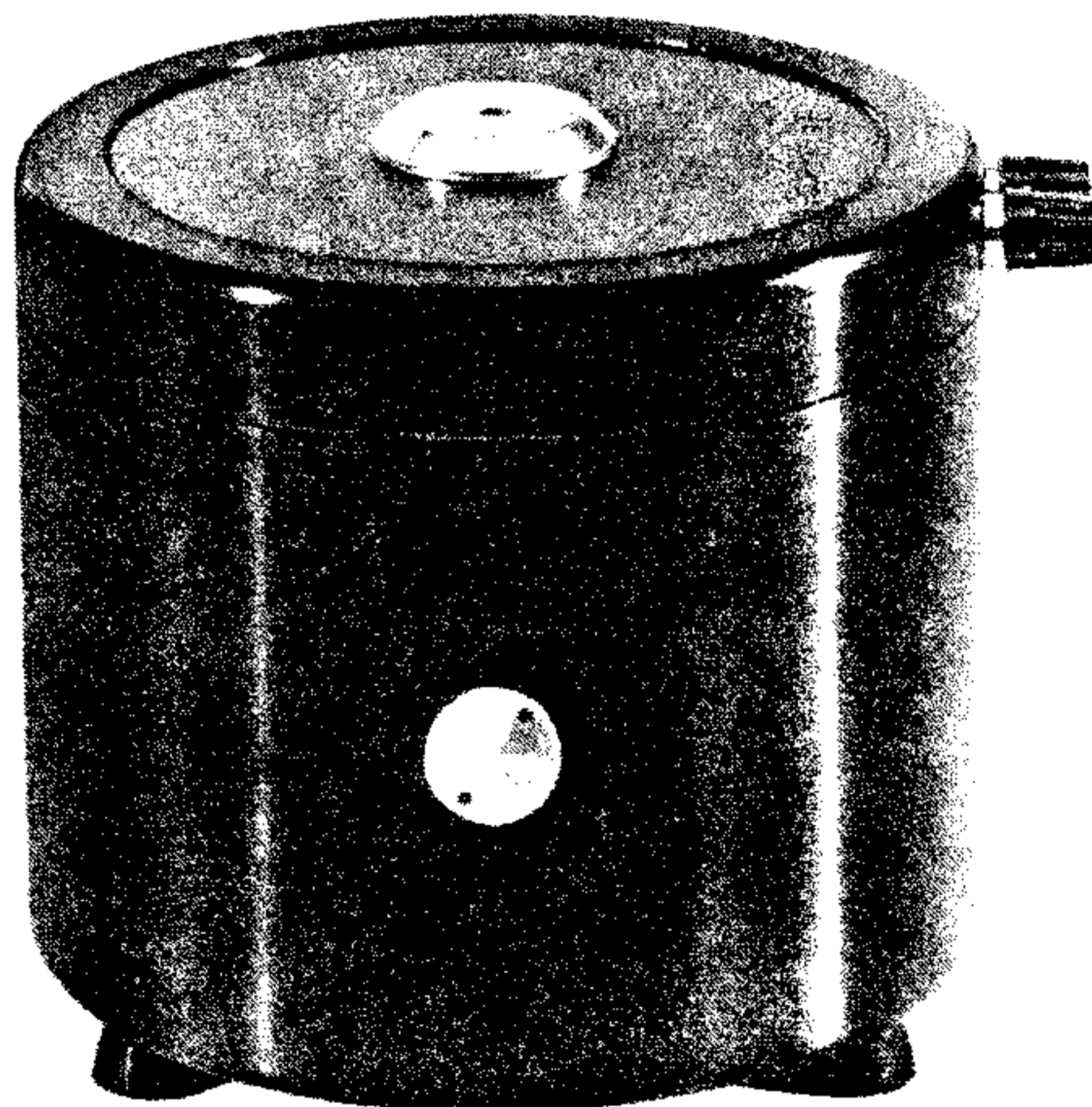
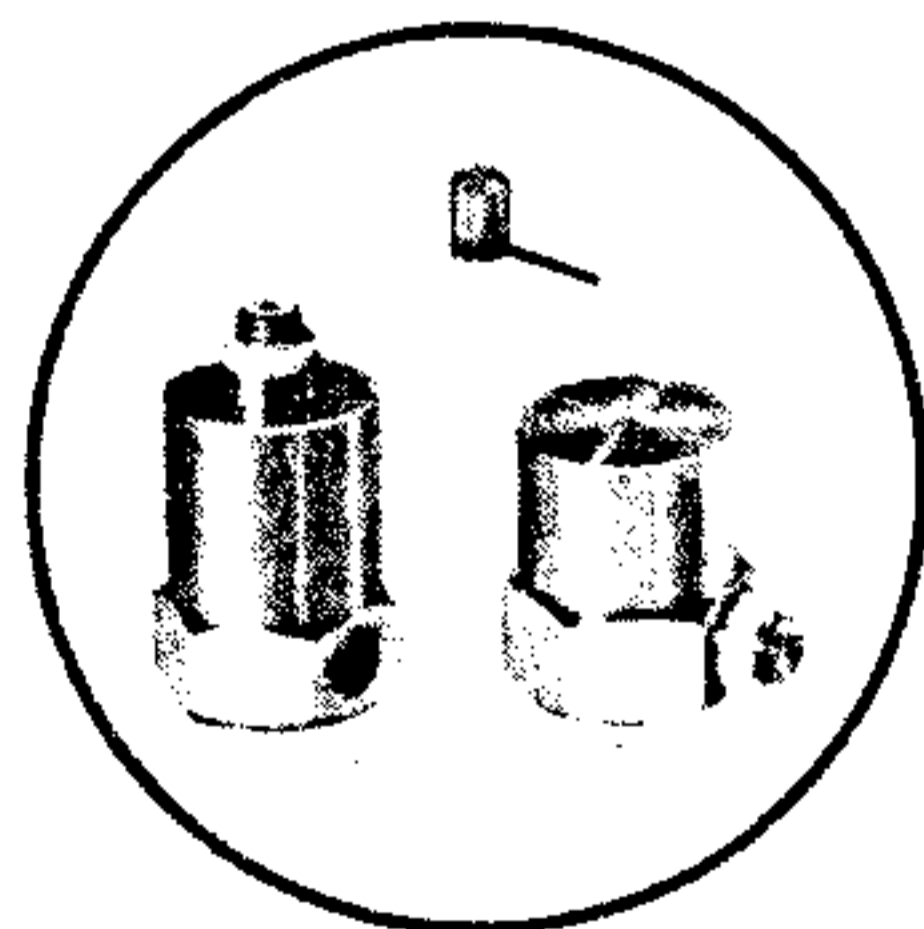
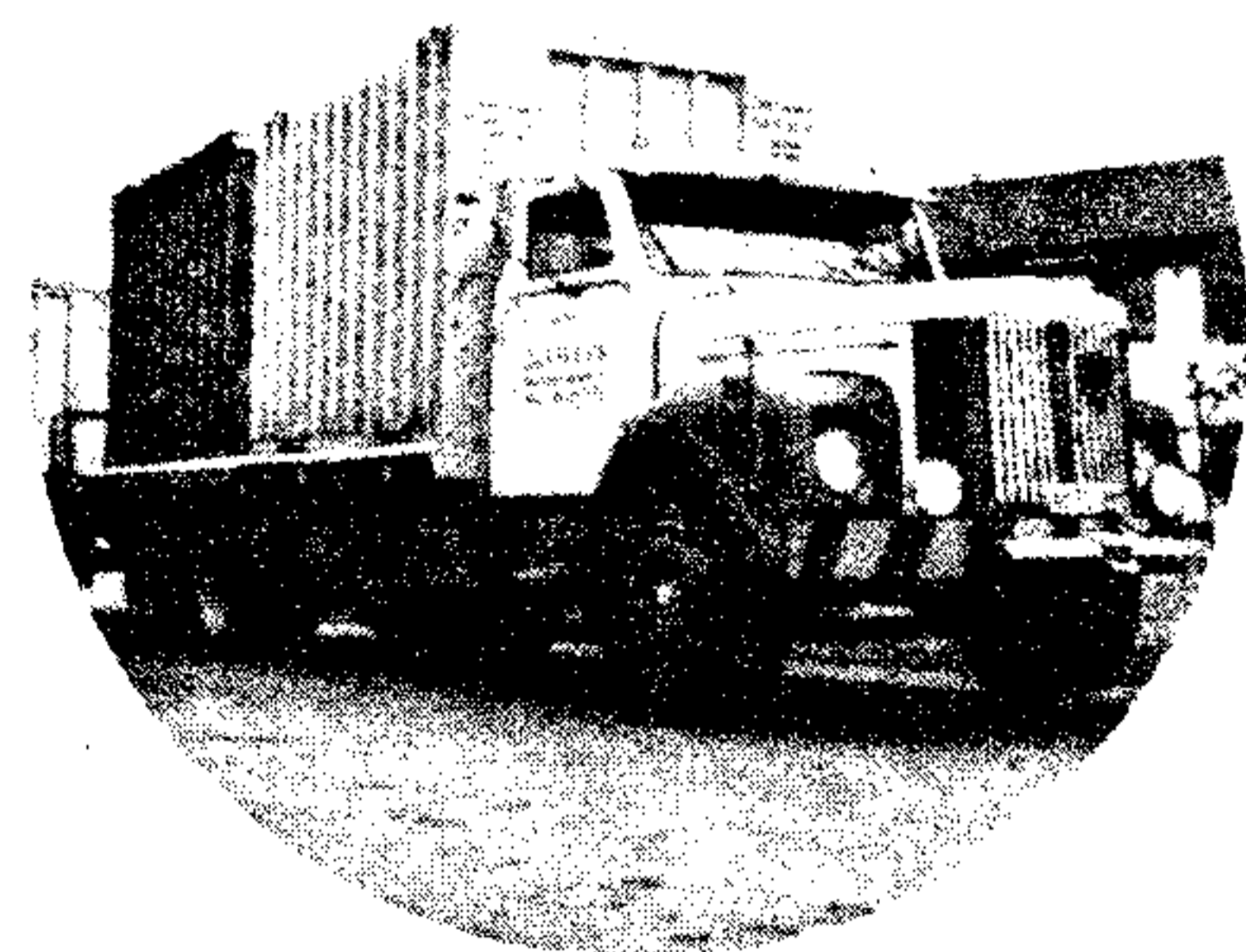
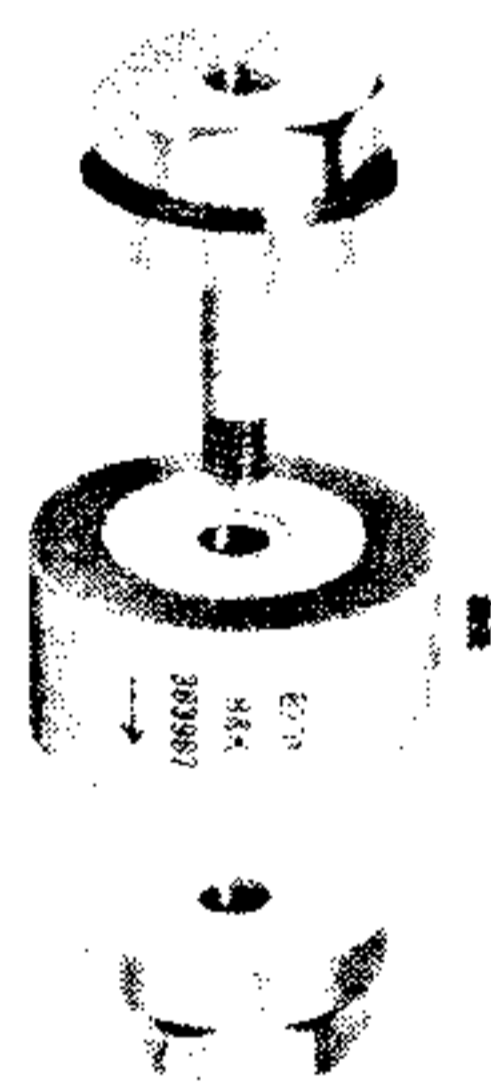
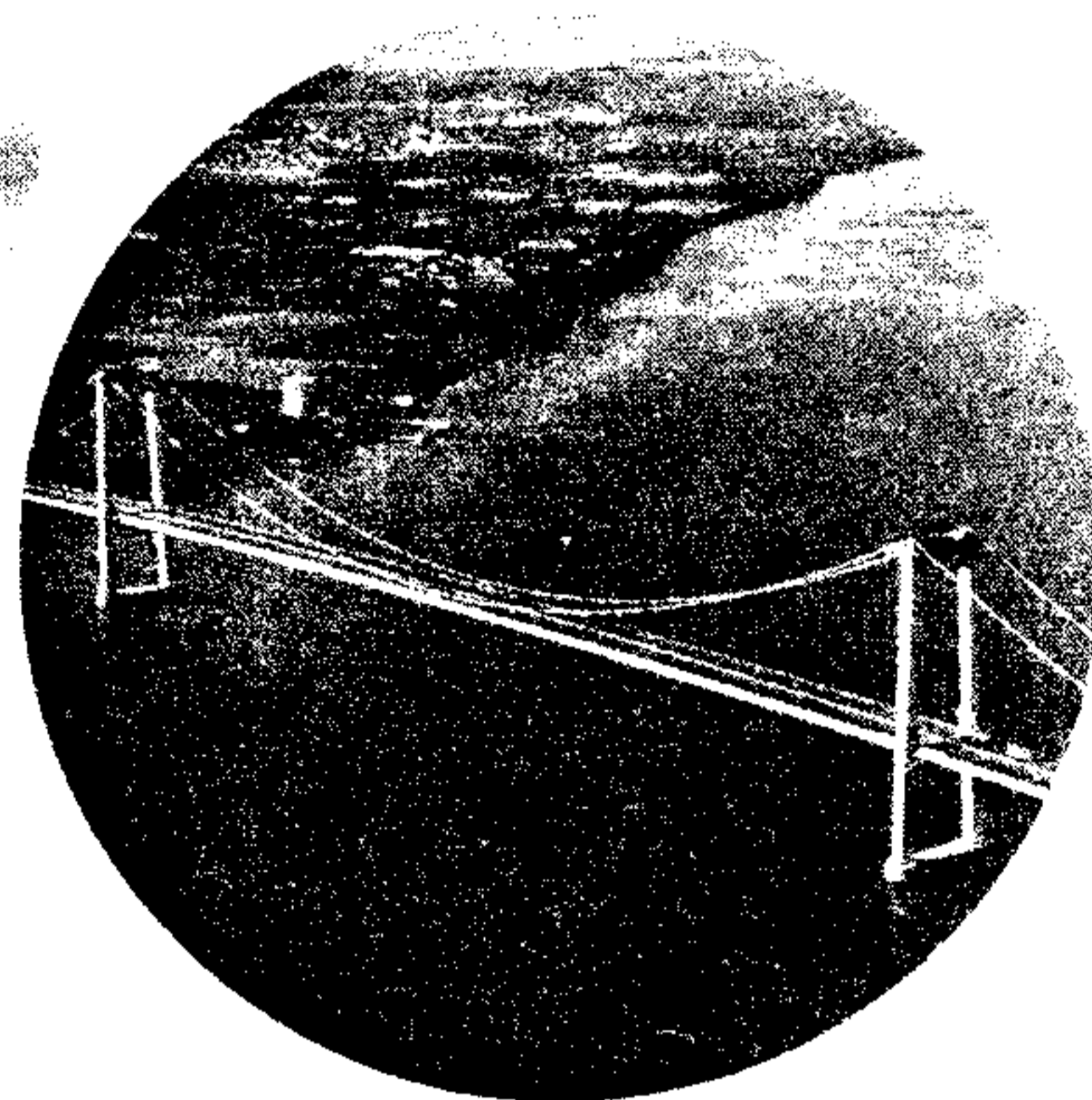
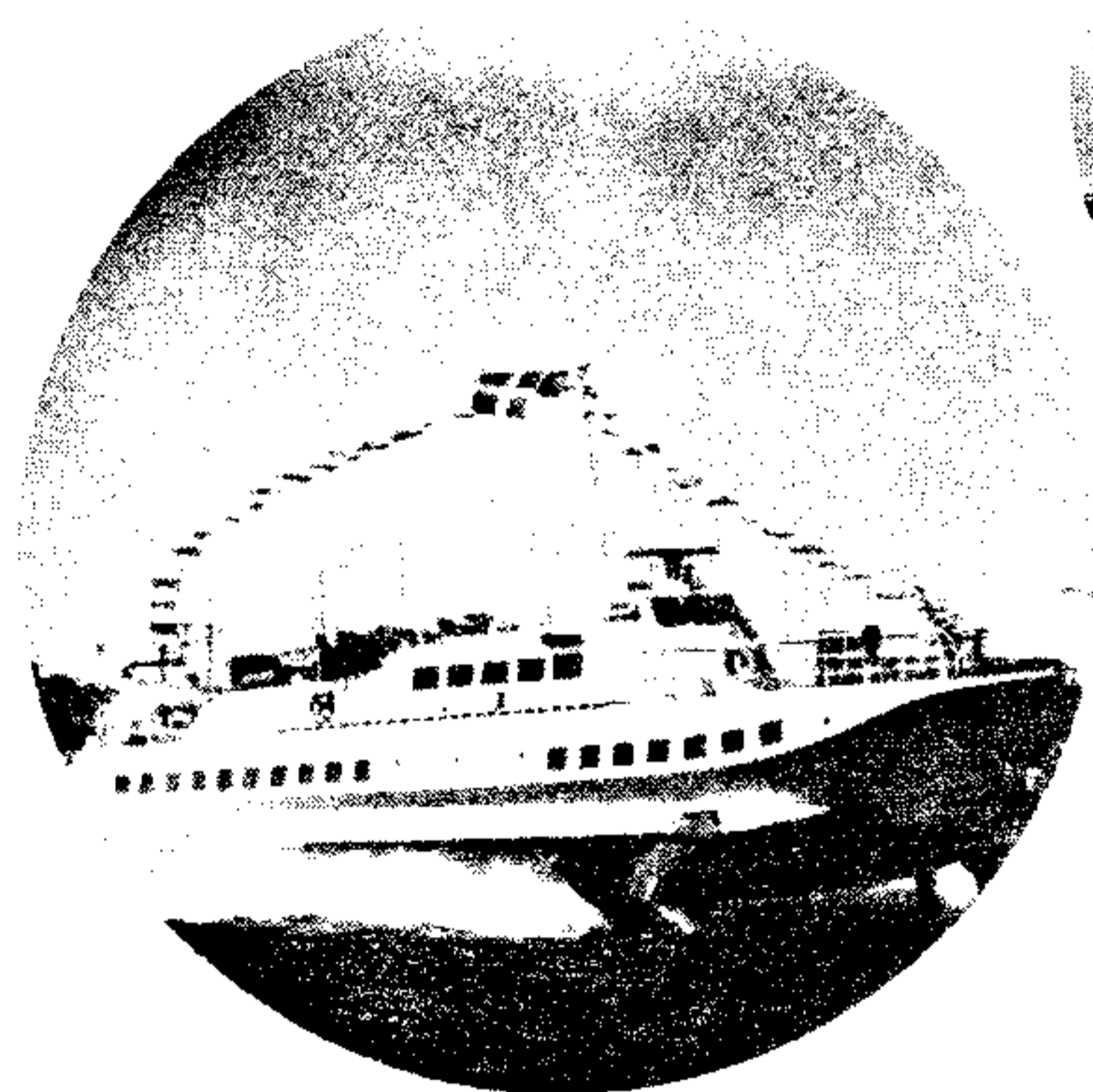

A Guide to Mechanical Impedance and Structural Response Techniques

by H. P. Olesen and R. B. Randall

Introduction

In recent years there has been a rapidly developing interest in the field of mechanical dynamics for a variety of reasons.

Firstly, the development of stronger materials and greater economy in design has led to increasingly lighter structures, more prone to vibration problems. At the same time, increasing rotational speeds also give increasing likelihood of having to deal with structural resonances.

Another important factor is the recent upsurge of interest in environmental questions since the improvement of both noisy and vibrating environments often can be simplified to a question of reducing the mechanical vibration, either at its source or somewhere along the transmission path.

Typical examples are provided by the transportation industries, where in the development of for example aircraft, automobiles and ships, care has to be taken not only that the various components can withstand the dynamic loadings to which they are subjected, but also

that the comfort of passengers is ensured.

An example of a different kind is given by the machine tool industry, where excessive vibration can severely limit the quality of machining and grinding operations.

The overall result is that the dynamic behaviour of a machine or structure is now an important factor in design and development along with the analysis of static stresses and deflections, and is normally studied in its own right, rather than just being allowed for in an excessive "safety factor", or treated as an afterthought when problems have been encountered.

One very useful experimental technique for the study of dynamic behaviour of machines and structures concerns the measurement of what is loosely termed "mechanical impedance". Broadly speaking, this defines the relationships between forces and motions at various points, both with respect to amplitude and phase. Ref. 10 lists the three main applications of impedance testing as:

1. Determination of natural frequencies and mode shapes.
2. Measurement of specific material properties such as damping capacity or dynamic stiffness.
3. As a basis of an analytical model. From measurements of the impedances of individual components or substructures it is possible to predict the behaviour of combined systems, in a manner completely analogous to the study of complex electrical circuits.

The concepts of mechanical impedance and mobility were developed from electro-mechanical and electro-acoustic analogies in the 1920's. Since then the usefulness of these concepts in forced vibration techniques and in the theoretical evaluation of structures has improved considerably. This is due partly to more sophisticated vibration transducers, vibration exciters and analysis equipment and partly to the acceptance in mechanical and civil engineering of mechanical impedance and related concepts so that they could be handled on their own without resorting to a previous conversion to electrical circuits.

Mechanical impedance and mobility

The mechanical impedance and mobility (for simple harmonic motion) are defined as the complex ratios of force vector to velocity vector, and velocity vector to force vector respectively. This is shown in Table 1 where, in addition, the similar ratios involving acceleration and displacement are given.

The terms given in the table are taken from the American Standard USAS S2.6-1963: Specifying the Mechanical Impedance of Structures (1). Other terms have been used by different authors but will

not be given here. The units after each ratio are SI-units*.

As both force and motion are vectors in space as well as in time care should be taken to define directions

of motion relative to the direction of force when this is not obvious from the measurement conditions or from the calculations.

* International Organization for Standardization (ISO).

Dynamic Mass (Apparent Weight)	$\frac{F}{a}$	$\left[\frac{Ns^2}{m} \right]$	(Acceleration through Force)	$\frac{a}{F}$	$\left[\frac{m}{Ns^2} \right]$
Mechanical Impedance	$\frac{F}{v}$	$\left[\frac{Ns}{m} \right]$	Mobility (Mechanical Admittance)	$\frac{v}{F}$	$\left[\frac{m}{Ns} \right]$
Stiffness	$\frac{F}{d}$	$\left[\frac{N}{m} \right]$	Compliance	$\frac{d}{F}$	$\left[\frac{m}{N} \right]$

Table 1. Terminology for complex dynamic ratios of force and motion

When force and motion values are measured at the same point and in the same direction the ratios are termed driving point values, or in short, point values, e.g., point impedance.

When force and motion are measured at different points or at the same point with an angle between them they are termed transfer values e.g., transfer impedance.

The ratios given in the first and second column of Table 1 really represent, as functions of frequency, the difficulty or ease, respectively, with which a structure can be set

into motion. By measuring, for example, the mechanical impedance of points on a structure, knowledge is gained about its response to vibrational forces at different frequencies. Similarly, a measurement of the motion of the structure, after it has been placed on a vibrating support, may be compared to its mechanical impedance to obtain information about the forces which act on the structure.

To solve vibrational problems, therefore, both a mechanical impedance may have to be measured, and a narrow band frequency analysis carried out to obtain detailed know-

ledge about the response ability of the structures involved, and of the actual responses or forces. After combination of this information the need or the possibility of corrective measures may be evaluated.

In the following sections, after a brief discussion of narrow band frequency analysis, rules are given for evaluating mechanical impedance data by graphical means, the instrumentation used for practical measurement is discussed and a few practical examples are given, as well as references to further literature about Mechanical Impedance applications.

Narrow Band Frequency Analysis

One of the major reasons for studying dynamic phenomena as functions of frequency is the simplicity that this introduces for linear systems, since many actual structures have approximately linear parameters (stiffness, damping, mass). One important property of such linear systems is that of superposition. In particular, an input at a given frequency gives an output at the same frequency, though modified in amplitude and phase according to the frequency response function, and the behaviour at this frequency is thus independent of what is going on at other frequencies. A related advantage is that combination of cascaded systems involves only multiplication of their characteristics at each frequency, and this in turn is simplified to addition when logarithmic (dB) amplitude scales are used. Even though excitation is rarely sinusoidal at a single frequency, the use of Fourier analysis (narrow band frequency analysis) makes it possible to break down a more complex signal into its components at various frequencies, thus considerably simplifying its interpretation.

A typical dynamic problem would involve obtaining the frequency spectrum of the input to a mechanical system (be it force or motion) and by comparing this with the measured response characteristics to determine whether a problem will arise due to coincidence of peaks in the excitation and mobility. The solution of such a problem would consist either in eliminating that component

from the source excitation, or in modifying the structure to "detune" or damp that particular frequency region.

The type of frequency analysis performed will perhaps be influenced by the approach chosen, and thus a brief discussion is given of the methods available for frequency analysis.

One of the first decisions to be made is between constant bandwidth and constant proportional bandwidth analysis. It is often claimed that "narrow band analysis" is synonymous with narrow constant bandwidth analysis, but this is not necessarily the case. For example the Analyzer Type 2120 has constant percentage bandwidths down to 1%, and this will often give adequate resolution. In fact, the response of mechanical structures tends to be similar in principle to a constant percentage bandwidth filter (a certain amplification factor Q corresponding to a certain percentage bandwidth). Thus, where the excitation is fairly broadband it may be most efficient to analyze the response with constant percentage bandwidth filters.

Another advantage of constant percentage analysis is that it gives uniform resolution on a logarithmic frequency scale, and thus can be used over a wide frequency range. As explained later, logarithmic scales are moreover advantageous for the interpretation of mechanical impedance data.

Where the Q -factors (see later for definition) are greater than about 50, however, it may be necessary to go to constant bandwidth filters, purely in order to obtain a bandwidth less than 1% in certain frequency ranges.

Constant bandwidth analysis (particularly on a linear frequency scale) is also beneficial for the analysis of excitations with a high harmonic content, since the harmonics are then uniformly separated.

The overall consideration in choice of analysis method is that it should everywhere give sufficient resolution, without giving too much information in other areas, because of the detrimental effect of the latter on analysis speed and efficiency. Frequency Analysis is covered in depth in Ref. 17.

Perhaps the best compromise is the Heterodyne Analyzer Type 2010 which has both linear and logarithmic frequency sweeps covering the range from 2 Hz to 200 kHz. Although it is primarily a constant bandwidth instrument it can be programmed to step up automatically in bandwidth with increasing frequency, thus approximating a constant percentage bandwidth analysis (where the percentage can be considerably lower than 1%). The main disadvantage of such an analyzer, viz. long analysis time, can be obviated by use of the Digital Event Recorder Type 7502 as described in Ref. 11. The large frequency trans-

formations available with this instrument (which incidentally can equally well be used with the Analyzer Type 2120) allow reduction of analysis time to the order of a minute or so, and also allow the effective bandwidth to be made smaller than the minimum available on the 2010 (3,16 Hz).

When even faster analysis is required, or where a very large num-

ber of spectra must be averaged to give a stable result, the Real-Time Narrow Band Analyzer Type 3348 will often be preferred. The real-time capability also gives the possibility of visually following non-stationary phenomena e.g., seeing how the response of a machine varies as it runs up or down in speed, and thus quickly establishing "dangerous" operating areas.

All the analyzers mentioned can write out a "hard copy" of the analysis results on a Level Recorder Type 2306, or 2307 which, as described later, can also be used for recording the impedance amplitude and phase characteristics. Output in digital form (ASCII-coded BCD) on punch tape is also possible.

Impedance and mobility of structural elements

The vibrational response of structures may in many cases be represented by a theoretical model which consists of masses, springs and dampers. If the structure is complicated and if the response must be duplicated exactly over a large frequency range the number of elements needed may be very large. However, for simple systems, and even for complicated structures in a limited frequency range, the response may be represented sufficiently well by a few elements.

The force F needed to set a pure mass m into vibration is proportional to the acceleration a .

$$F = ma \quad [N] \quad (1)$$

The force required to deflect a spring with stiffness k is proportional to the relative displacement d of the two ends of the spring

$$F = kd \quad [N] \quad (2)$$

Finally the force is proportional to the relative velocity v of the two ends of a damper with damping coefficient c for pure viscous damping.

$$F = cv \quad [N] \quad (3)$$

For sinusoidal motions, acceleration, velocity and displacement measured at a given point are related by the relationships

$$a = j\omega v = -\omega^2 d \quad (4)$$

$$v = j\omega d = (1/j\omega)a \quad (5)$$

$$d = (1/j\omega)v = (1/-\omega^2)a \quad (6)$$

here $\omega = 2\pi f$
and f is the frequency of vibration

The graphical signatures for the

three elements are given in Fig.1 together with their mechanical impedance and mobility.

Note that the mass is free in space and that the spring and damper require one end fixed in order for the absolute motion of the excited

end to correspond to the relative motion between their ends. They are considered massless. In cases where both ends of a spring or damper move, then it is the difference between the absolute motions of their ends which must be substituted into equations (2) and (3).

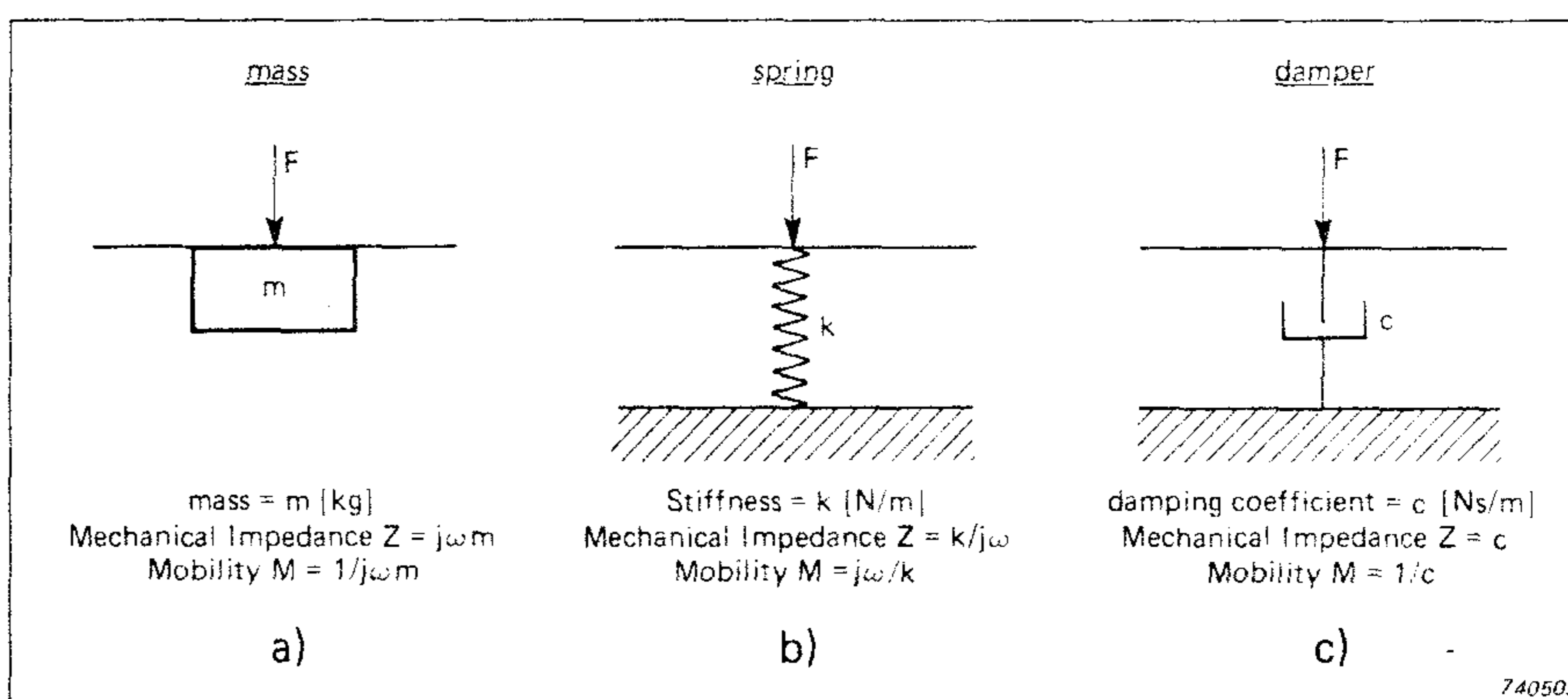

Fig. 1. Signatures for the basic elements

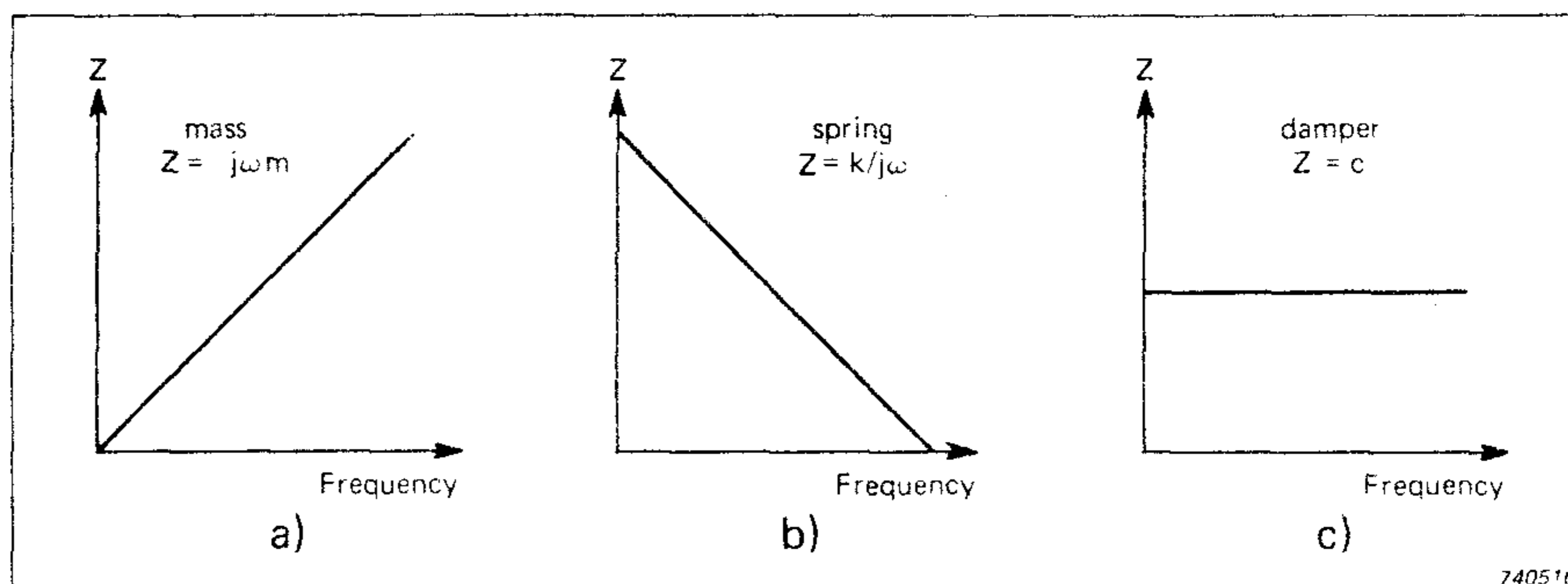

Fig. 2. Mechanical impedance for mass, spring and damper

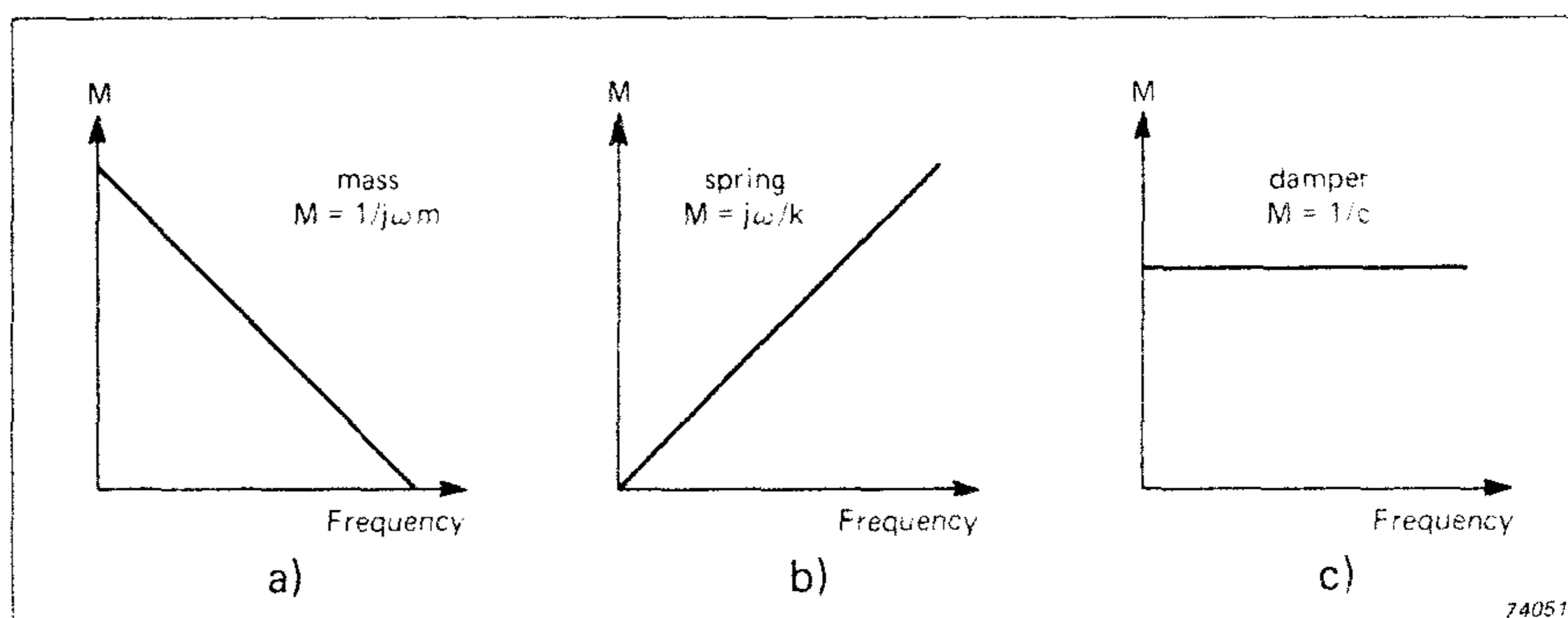

Fig. 3. Mobility for mass, spring and damper

The impedances and the mobilities of the elements are best illustrated in log-log diagrams with frequency $f = \omega/2\pi$ as the abscissae. In

this representation the impedances and mobilities are given as straight lines. (See Figs.2 and 3 where a factor of 10 equals the same dis-

tance on both abscissae and ordinates and whereby the slopes for mass and spring impedance lines are +1 and -1 respectively).

Combination of elements

A mass supported on springs is a common case in practice. e.g., in vibration isolation. In simple systems the mass can be considered to be placed on one spring which has a stiffness value equal to the sum of stiffnesses of the supports. (Damped systems will be considered later).

In the literature this basic system is very often symbolized as in Fig.4a for force applied to the mass as for instance with a motor placed on springs. However, this representation may lead to the misconcep-

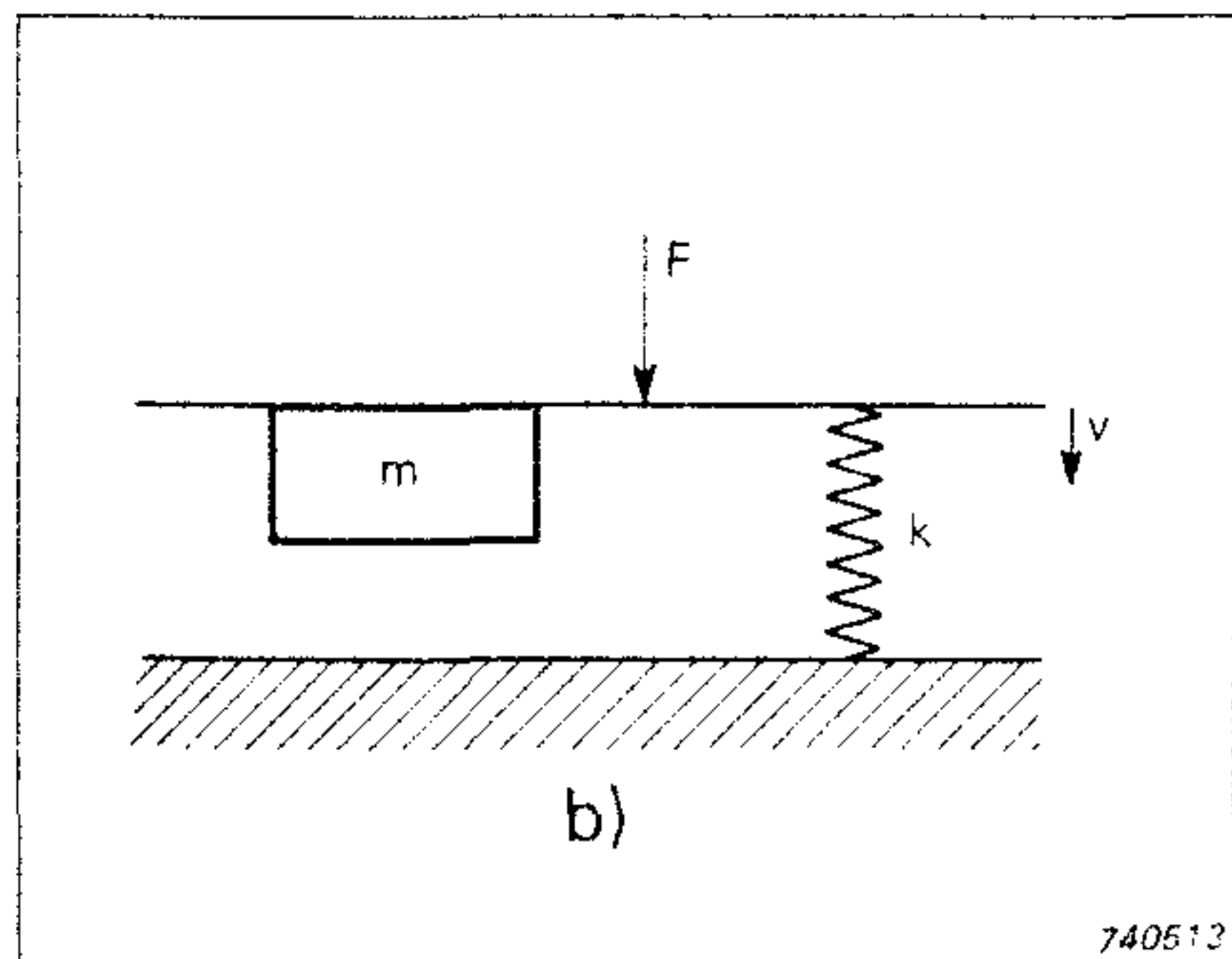
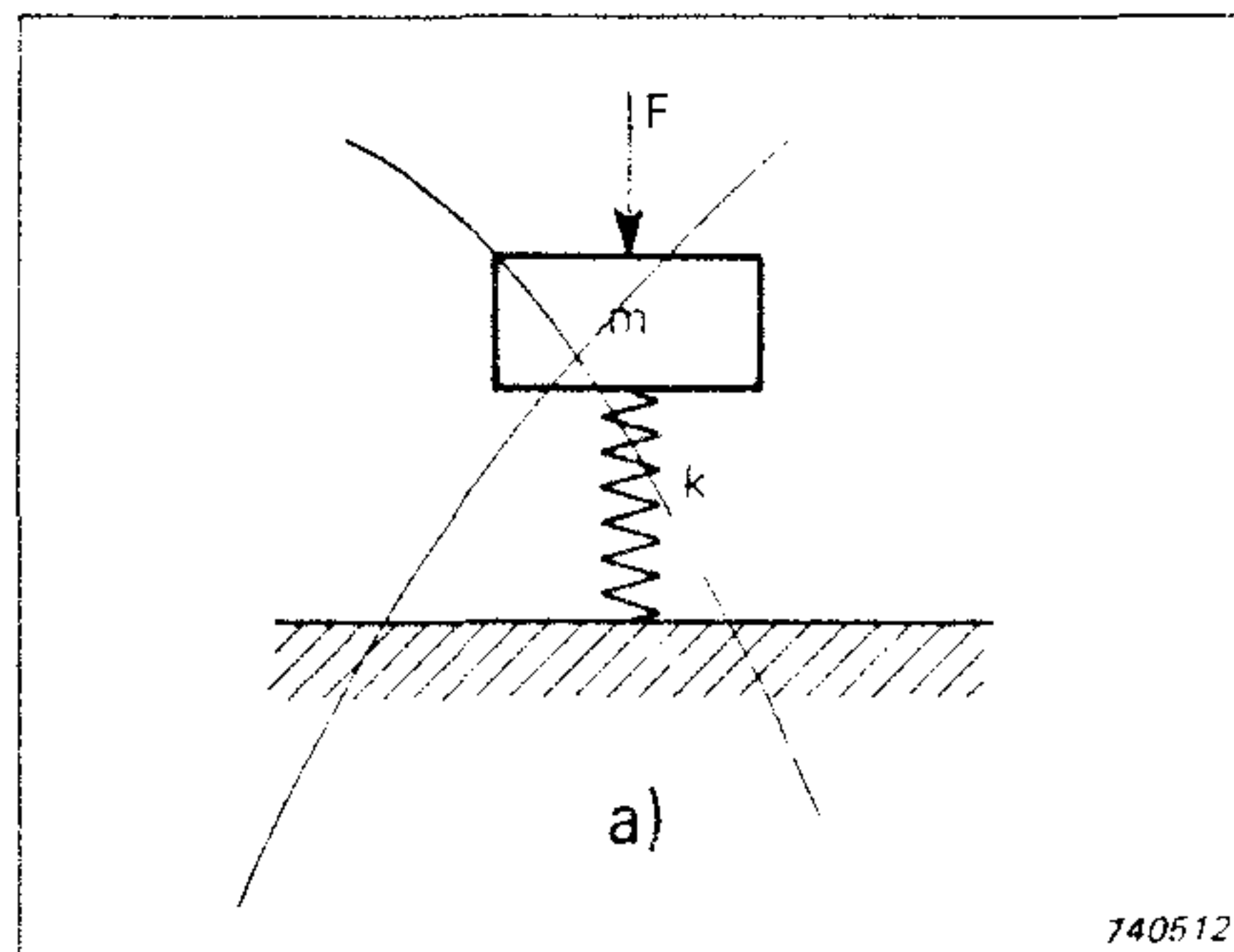

Fig.4. A mass supported on a spring shown in an often used representation (a) and in the correct way (b)

tion that the system is a so-called series system while it is, in fact, a parallel system where the force is shared between the mass and the spring as indicated clearly in Fig.4b. Here the force is applied to a moving plane to which both the mass and the spring are attached. (See Ref.2).

As the motion is common to the two elements their impedances (from Table 2) can be added to obtain the point impedance.

$$Z = Z_m + Z_K = j\omega m + k/j\omega \quad (7) \\ = j(\omega m - k/\omega)$$

At low frequencies ω is very small and Z equals $k/j\omega$ as $j\omega m$ can be neglected. At high frequencies ω is large and Z equals $j\omega m$.

At a frequency f_R where $j\omega m = -k/j\omega$ a resonance occurs where $Z = 0$ and $\omega = \omega_0 = \sqrt{k/m}$.

The impedance can be plotted

from equation 7 but it is less time consuming to combine the curves graphically. (Remember that the mass impedance has a positive phase angle of 90° (j) and the spring impedance has a negative phase angle of 90° ($-j$ or $1/j$) relative to the force). The curves can be obtained by subtracting the lowest value from the highest value at each frequency but a more straight forward method is to construct a so-called impedance skeleton, as given by Salter (2). This is shown in Fig.5b where the spring and mass lines are combined up to their intersection at f_R where they counteract each other to produce a vertical line for $Z = 0$.

The impedance curve can then be drawn to the desired accuracy by determining two or more points from the spring and mass curves and drawing a curve through the points from the skeleton values at $0,1 f_R$, f_R and $10 f_R$ (Fig.5c).

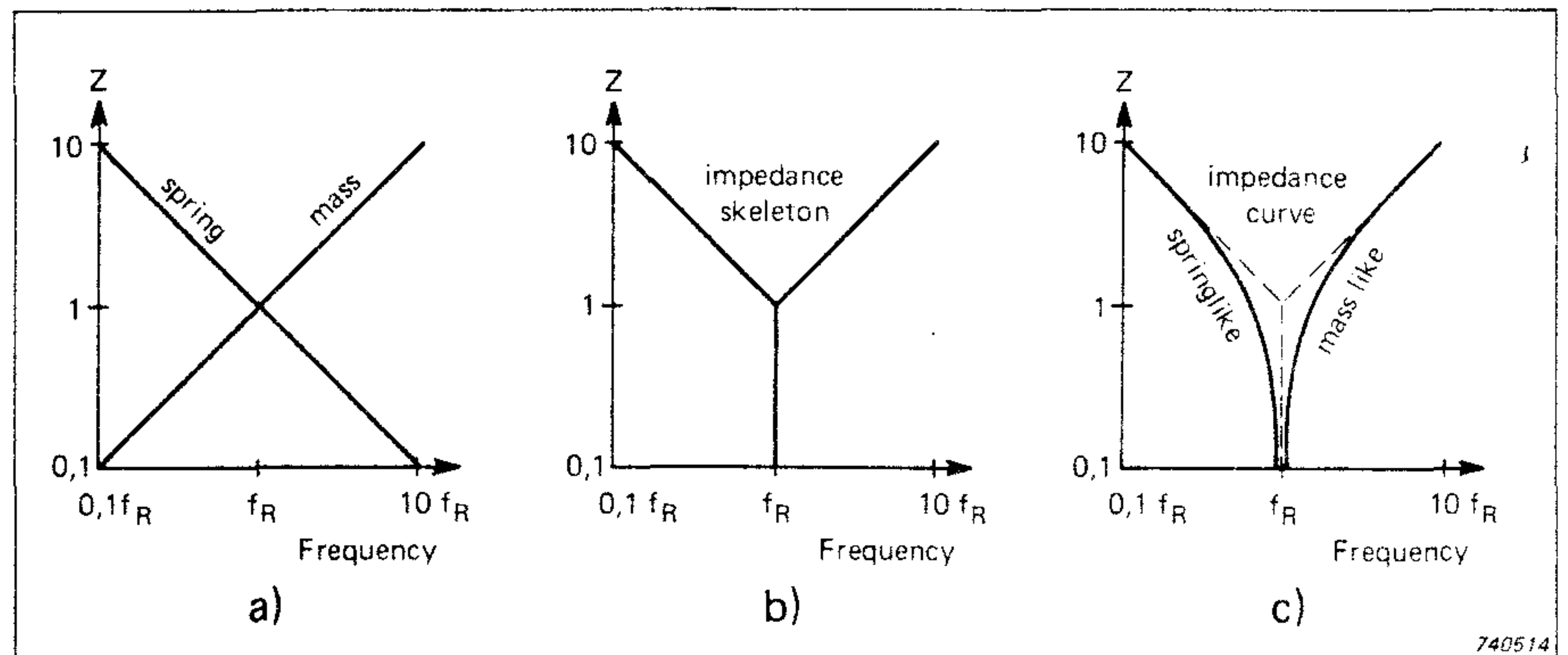

Fig.5. Graphical construction of the mechanical impedance of a mass supported on a spring

Base excited system

If the system of Fig.4 is excited at the base as shown in Fig.6 it is seen that the velocities at the base and at the mass are different, i.e., both point and transfer values do exist. As the force on the mass is equal to the force at the base the system can best be evaluated from the mobilities of the mass and the

spring. These are directly taken by inversion of the impedance curves of Fig.5 (see Fig.7a).

From these curves the point mobility skeleton and the point mobility curve can be constructed in a similar manner to the impedance curve of Fig.5c (see Fig.7b).

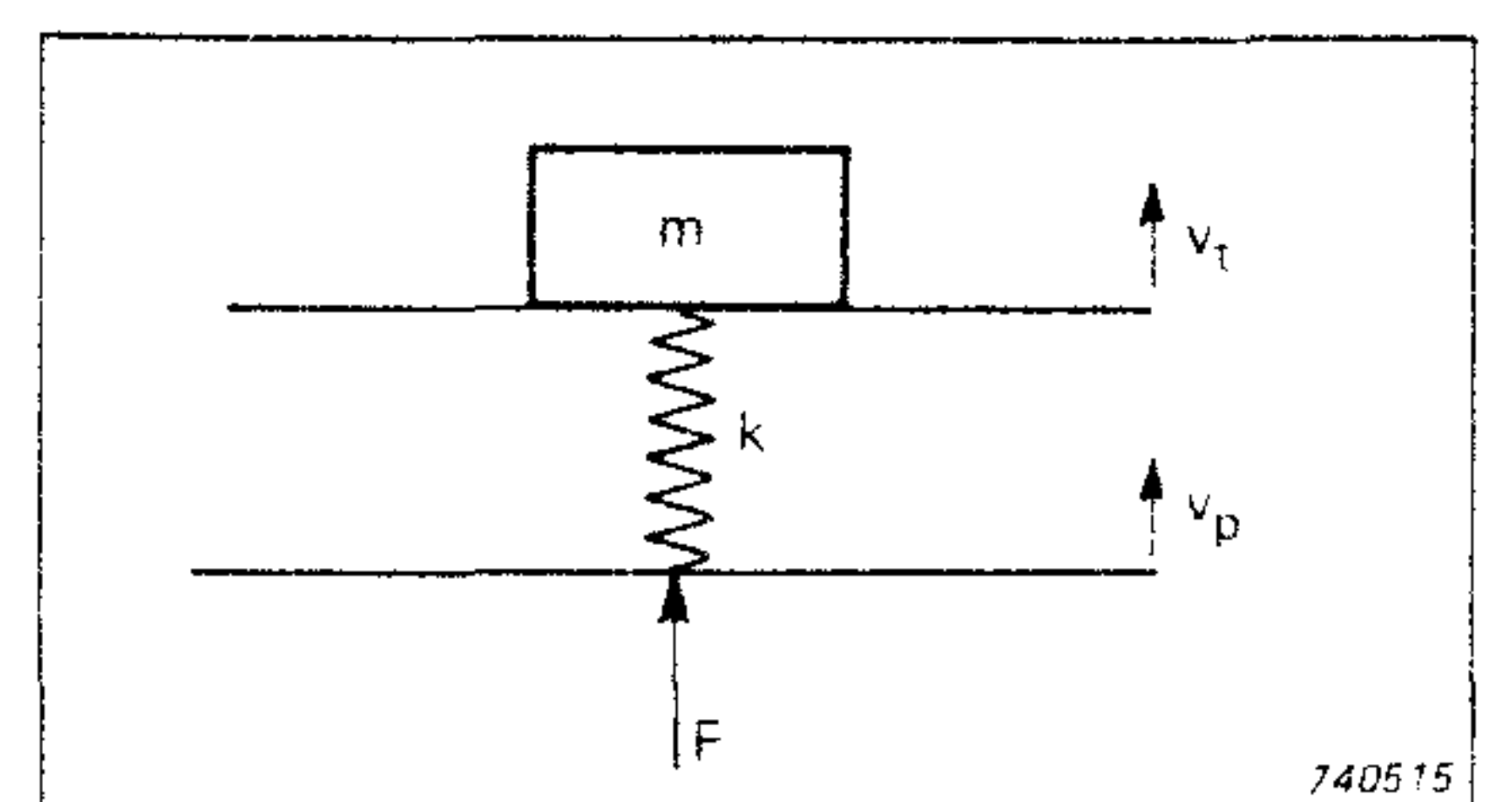

Fig.6. Base excited system

However, it is a mobility plot and the minimum at f_A represents an antiresonance, i.e. an infinite force would be required to produce any motion at all.

The transfer mobility, on the other hand, experiences no discontinuity. As the force transmitted through the spring remains constant and equal to F the velocity V_t of the mass remains the same as it would be for a mass suspended in space and hence the transfer mobility is a straight line with the same slope and position as a point mobility curve for the mass alone. The motion of the mass being reduced rapidly suggests that at high fre-

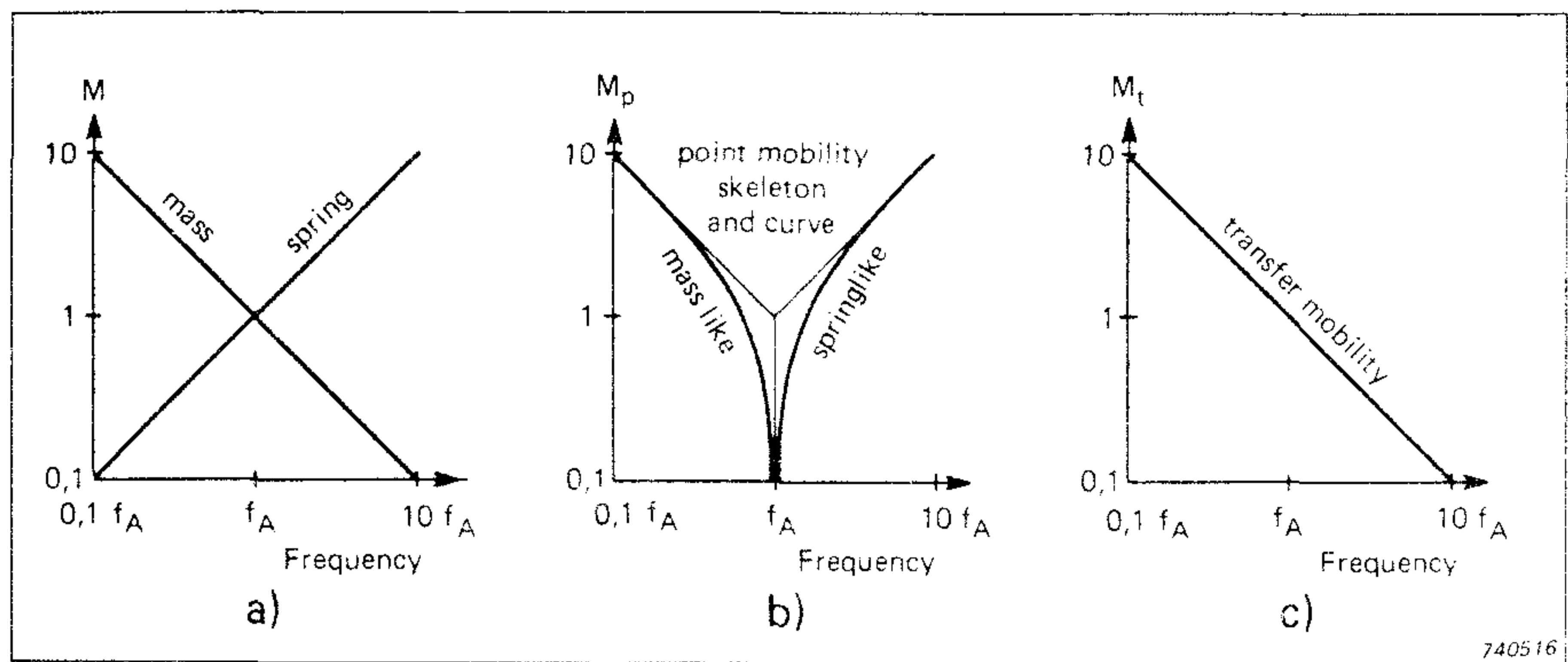

Fig. 7. Point mobility and transfer mobility for a base excited system

quencies to all practical purposes the spring can be considered as

placed on a rigid support as that of Fig.1b.

The mass-spring-mass system

An example of further extension of the model is given by the evaluation of the mass-spring-mass system which is often encountered. This system is shown in Fig.8, and it is seen that the force is divided between the mass and the spring supported mass (the sprung mass). Hence, the point impedance must be found from the combination of the mass impedance line (shown for three different masses in Fig.9), and the point impedance skeleton of the sprung mass which has antiresonance at f_A . The point impedance skeleton is obtained by inversion of the point mobility skeleton of Fig.7b and is shown in Fig.10. The resulting point impedance skeletons and

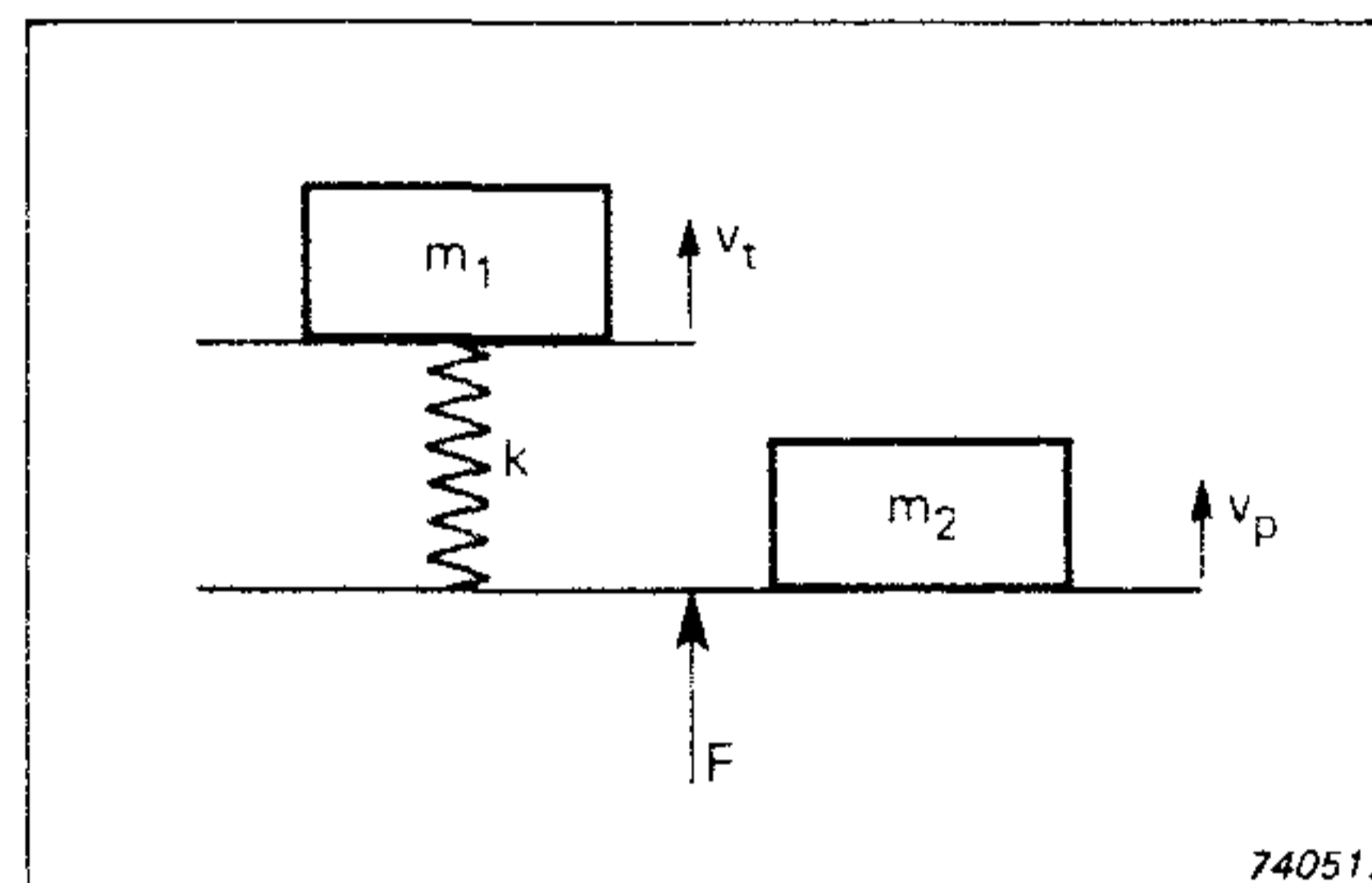

Fig. 8. A mass-spring-mass system

curves for the three values of m_2 are given in Fig.11.

It is seen that the impedance is obtained by the combination of the curves in Figs.9 and 10 by keeping the highest value and by letting the

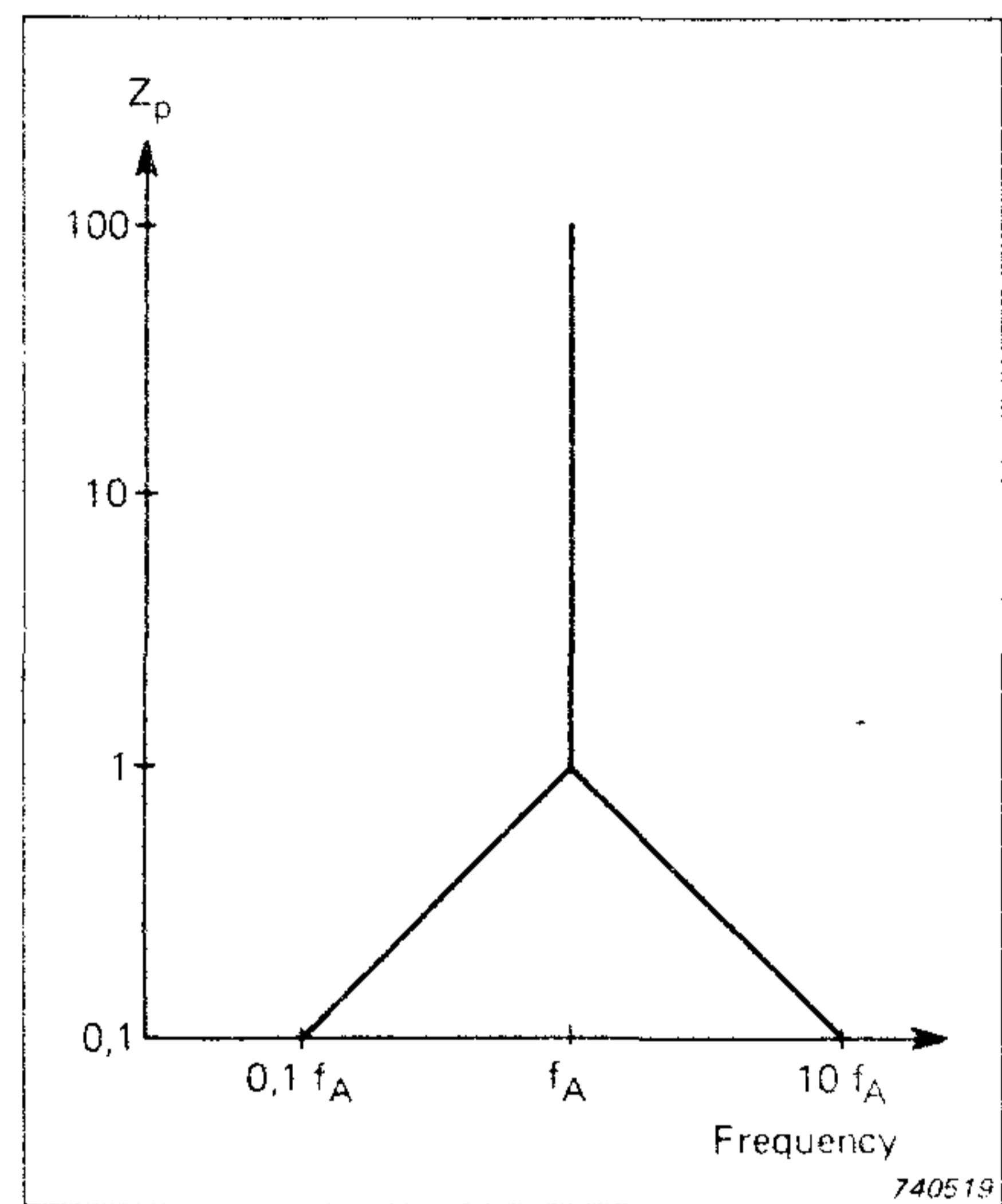

Fig.10. Point impedance skeleton of the sprung mass shown in Fig.6

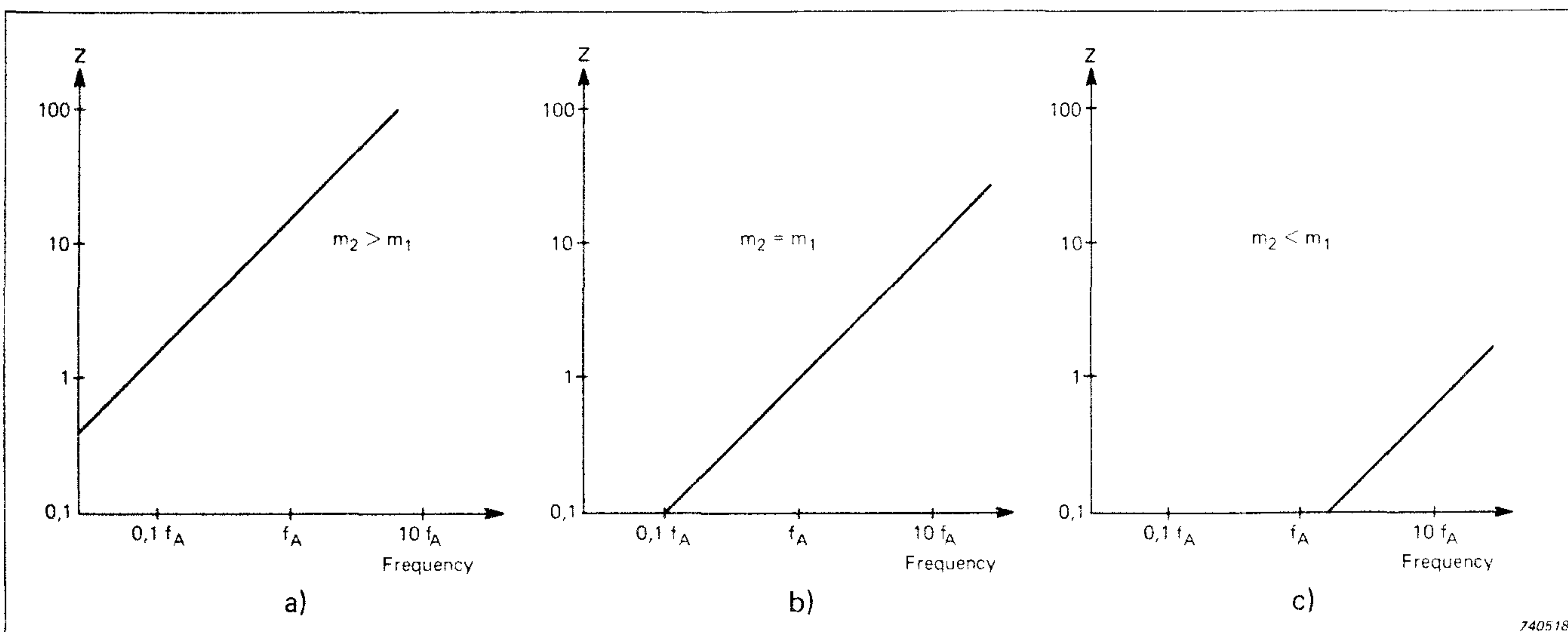

Fig. 9. Mass impedance lines for three values of m_2 drawn to the same scales as used in Figs.10 and 11

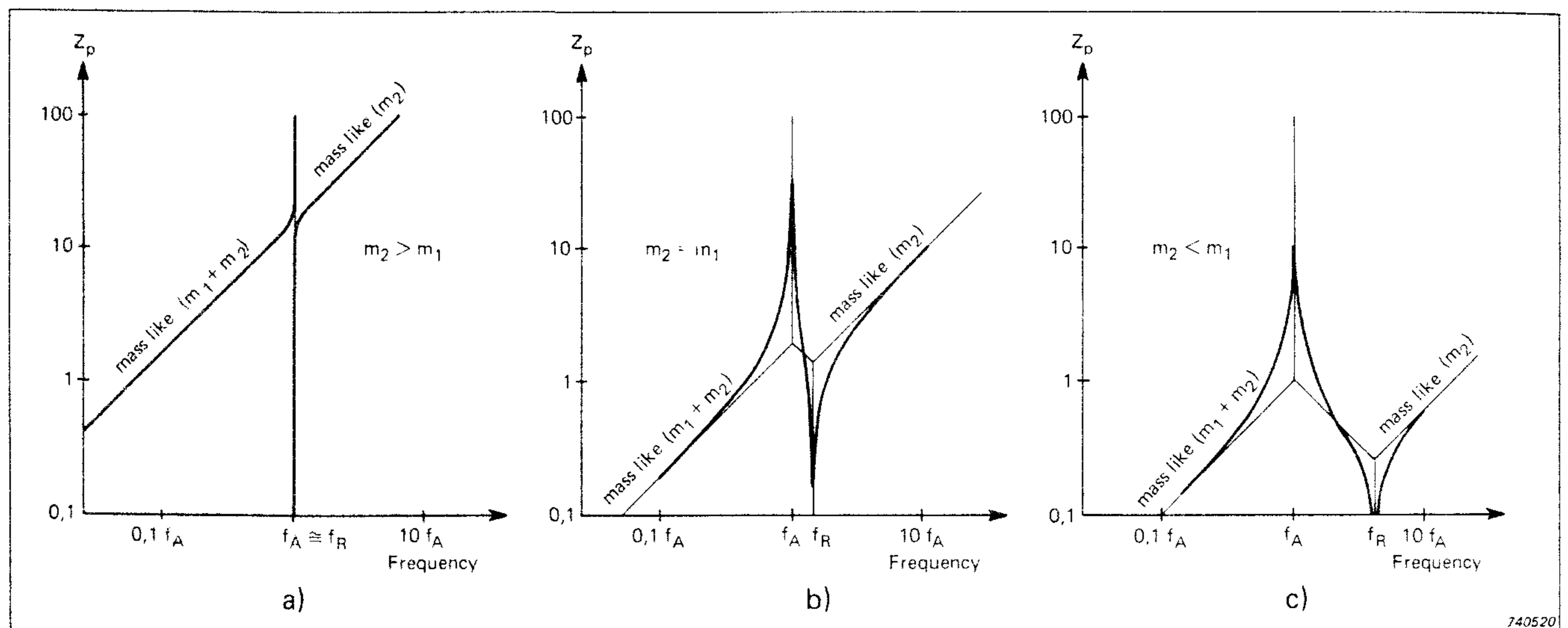

Fig. 11. Point impedance for the mass-spring-mass system for three different ratios of m_2/m_1

values go to infinity at the antiresonance and to zero at the resonance. Thereby the so-called peak-notch response curve is obtained. That this is the case can be derived from the fact that at the antiresonance the point impedance switches instantaneously from an infinitely high mass value to an infinitely high stiffness value which is negative (180° phase shift) with respect to the impedance of m_2 . As the high stiffness value is reduced with increasing frequency the point impedances of the sprung mass and m_2 will compensate each other at the resonance to produce zero impedance.

In Figs. 11a, 11b and 11c it is seen that the curves commence as mass like impedances with respect

to $m_1 + m_2$ and after the peak-notch they continue as impedances with respect to m_2 as m_1 is now decoupled. Between the peak and the notch there is an interval in which the impedance is springlike.

The frequency of antiresonance is equal to

$$f_A = (1/2\pi) \sqrt{k/m_1} \quad (8)$$

and the frequency of resonance is

$$f_R = (1/2\pi) \sqrt{k(m_1 + m_2)/m_1 m_2} \quad (9)$$

and it is seen that

$$\text{for } m_2 \ll m_1; f_R = (1/2\pi) \sqrt{k/m_2} \quad (10)$$

$$m_2 = m_1; f_R = (1/2\pi) \sqrt{2k/m_1} = \sqrt{2} f_A \quad (11)$$

$$m_2 \gg m_1; f_R \cong (1/2\pi) \sqrt{k/m_1} = f_A \quad (12)$$

Disregarding for the moment the point impedance curve it can be seen that to maintain a constant transfer velocity V_t below and over the antiresonance, the force F must be $j\omega(m_1 + m_2) V_t$ and, hence, the transfer impedance value continues as a straight line with slope +1 across the antiresonance (see Fig. 12).

At the resonance, however, it is seen from the point impedance curve that no matter which velocity V_p (and thereby the force input to the sprung mass) is chosen the total input force is zero. Hence the transfer impedance also goes to zero. Above the resonance the point impedance slope changes to +1, compared to -1 before the reso-

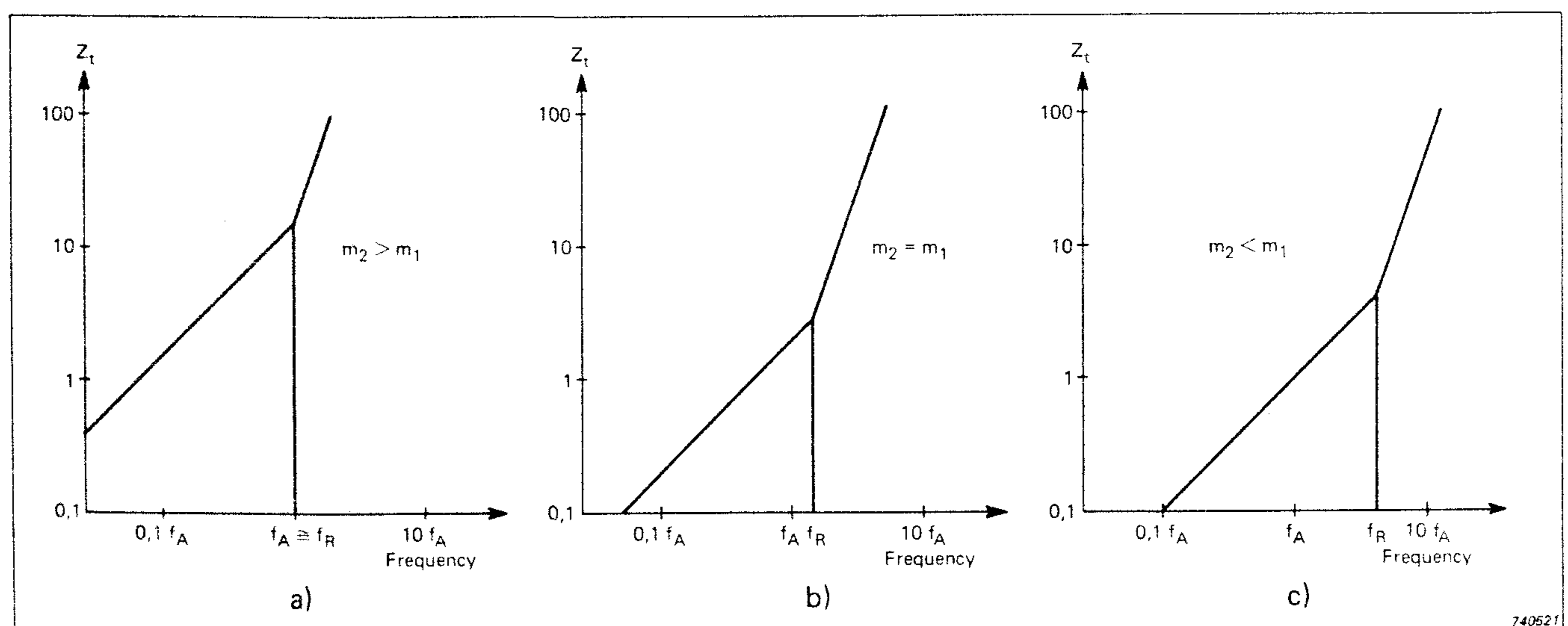

Fig. 12. Transfer impedance skeletons for the mass-spring-mass system

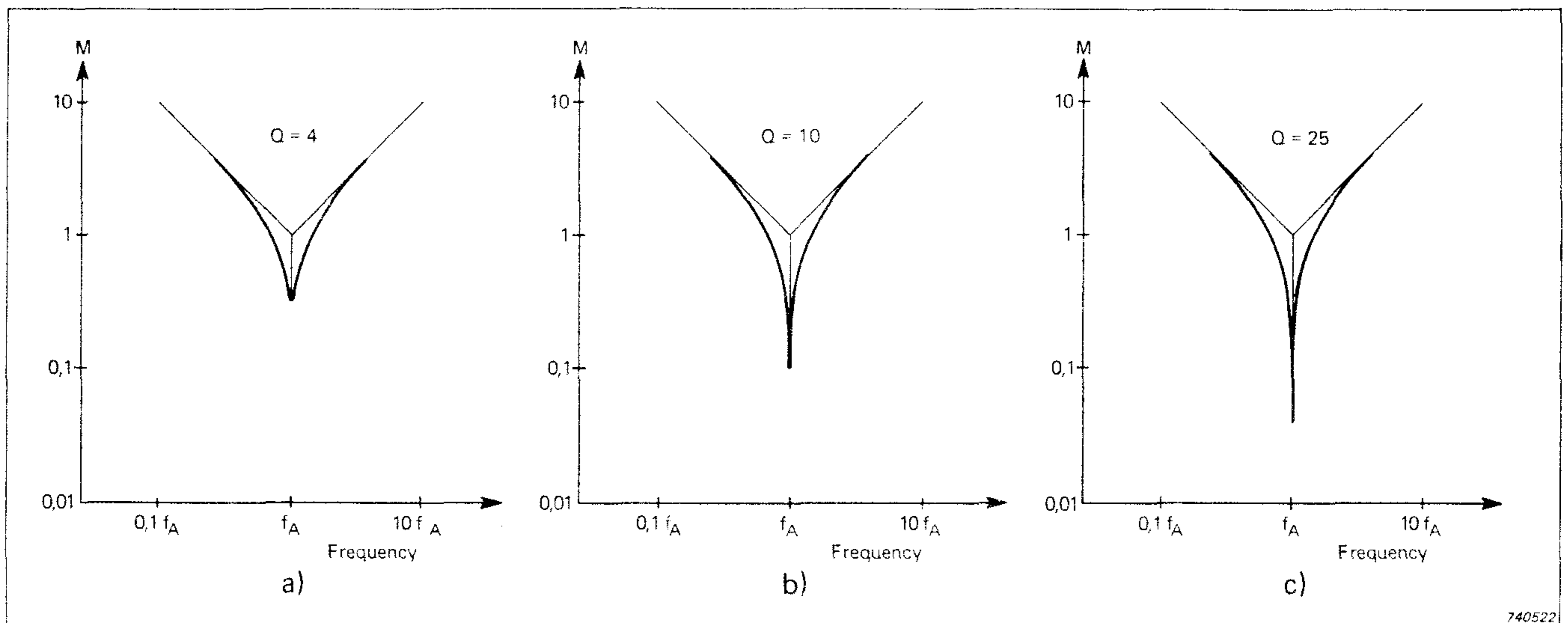

Fig.13. Damped mobility curves

nance. As the total force required to keep V_p constant, and thereby keep the force input to the sprung mass constant, must experience a similar change of slope the transfer impedance slope will increase from +1 to +3. From the impedance skeletons in Figs.11 and 12, the mobility skeletons can be obtained by sim-

ple conversion as

$$M = 1/Z \quad (13)$$

By adding subsystems to the system in Fig.8 or by letting itself be part of a larger model the total response can be evaluated by combining either impedance or mobility skeletons following the rules given

above. In this respect reference (2) by Salter is valuable as it extends the discussion to larger systems and to systems with more than one axis, and describes the inclusion of simple rotary systems. Similarly it discusses the influence of damping on the impedance and mobility curves which is treated below.

The influence of damping

On most structures which have not been treated specifically to be highly damped one must expect rather low damping values, and consequently high mechanical amplifi-

cation factors Q . In simple viscoelastic systems only

$$Q = c / \sqrt{km} \quad (14)$$

The amplification factor, as its

name implies, represents the factor with which to multiply or divide* the intersection values between mass and stiffness lines in the mobility diagram to obtain the mobility values

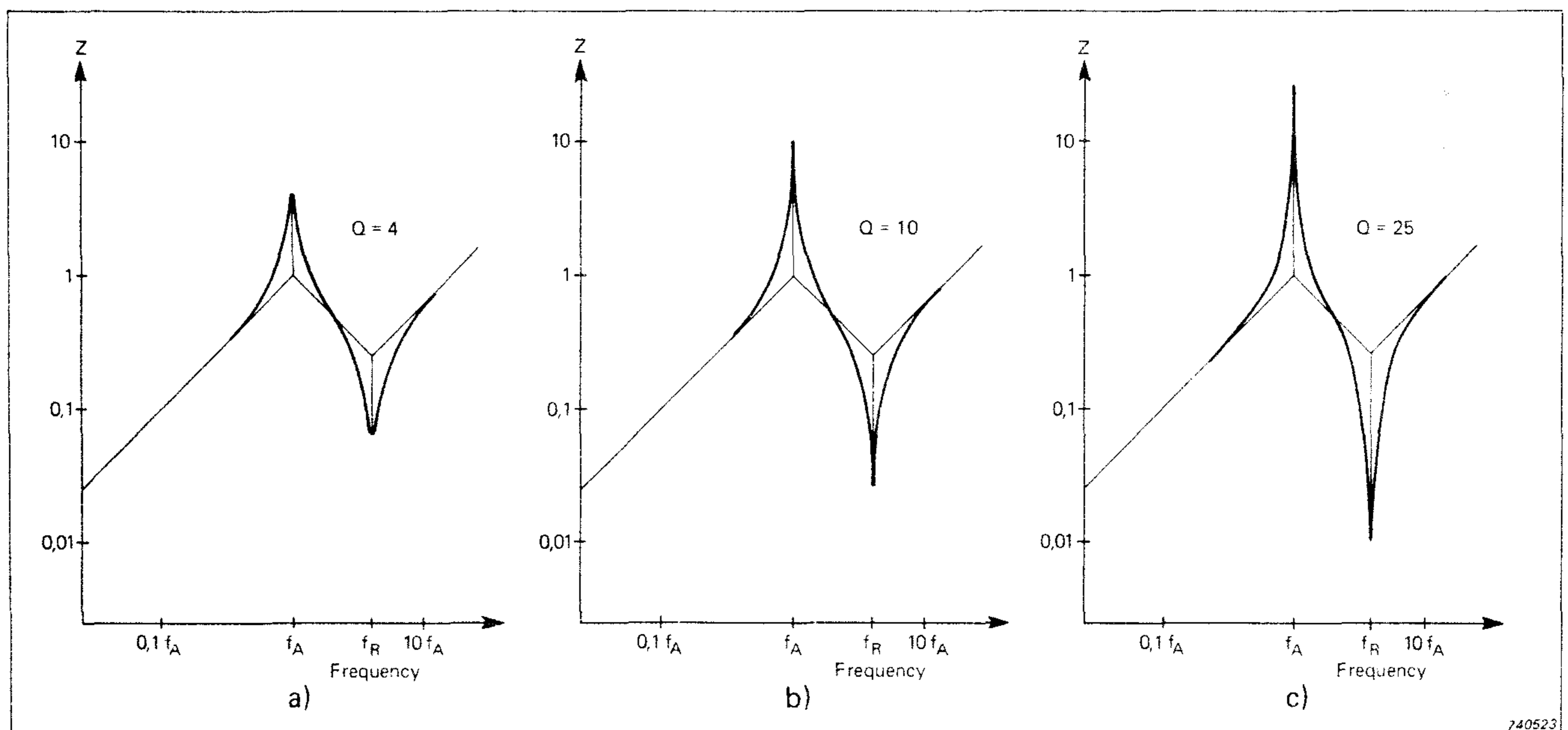

Fig.14. Damped impedance curves

* For systems with closely spaced antiresonances and resonances the Q value should be applied to the antiresonant subsystems before combination with other elements.

of the resonances and the antiresonances respectively, and vice versa for the impedance values. This is illustrated in Figs.13 and 14 where the mobility curve from Fig.7b and the impedance curve from Fig.11b have been redrawn for Q values of 4, 10 and 25.

Q values of 4 to 10 are often experienced for e.g. masses placed on rubber isolators. Other isolating materials used in compression may provide Q factors around 10 while many other mechanical engineering or civil engineering constructions are found with Q values in the range from 10 to 25. However, for integral metal constructions as for example castings or parts cut or

formed from one piece of raw material the Q values found may range to more than a hundred.

On the other hand, sandwich constructions with viscoelastic layers in shear, specially designed dampers or even materials with high integral damping, may provide Q values considerably lower than 4. When the Q value is 0,5 or smaller, the system is said to be critically damped (see Fig.15) i.e. after a forcing function has been discontinued the vibration amplitude will die out without any oscillations. All systems with higher Q will oscillate at their resonance frequency for a shorter or longer period after excitation depending on the Q value.

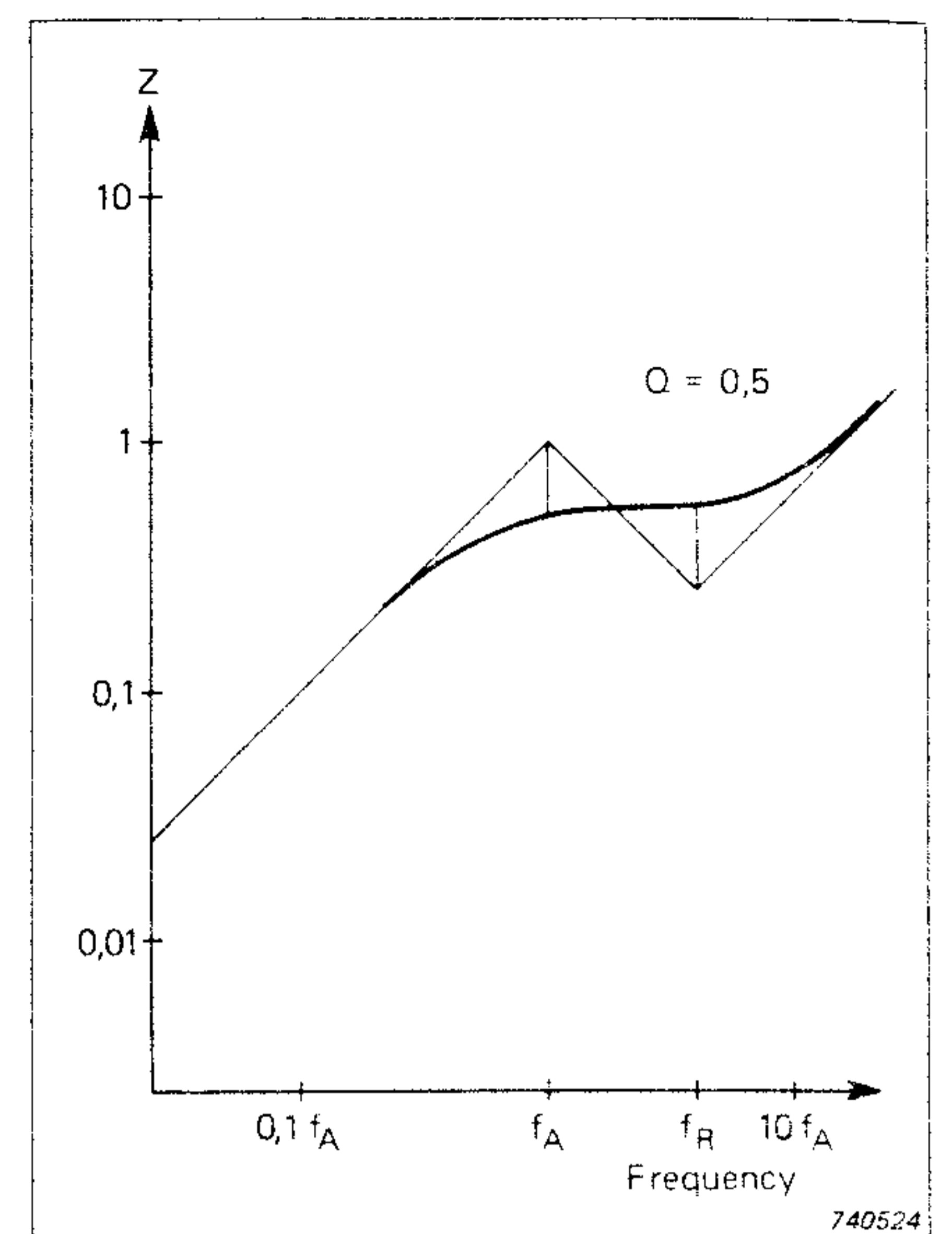

Fig.15. Critically damped impedance curve

Phase relationships in mechanical impedance and mobility

In the above sections the phases of the different impedances and mobilities have only been briefly mentioned. However, it may be useful to consider the phase relationships as they may prove important in some applications.

If the phase of the exciting force is taken as reference it is seen from the unity vector diagram Fig.16 that the velocities of the mass, the spring and the damper of Fig.1 respectively have -90° , $+90^\circ$ and 0° phase shift ($-j$, $+j$, $+1$).

As the impedances and mobilities are given by

$$Z = F/v \text{ and } M = v/F = 1/Z \quad (15)$$

their phases are found from

$$\angle Z = \angle F - \angle v \quad (16)$$

and

$$\angle M = \angle v - \angle F = -\angle Z \quad (17)$$

As an example the angle of the impedance of the mass is (see Fig.17)

$$\angle Z_m = 0^\circ - (-90^\circ) = +90^\circ \quad (18)$$

In all undamped cases it is very simple to find the phase of the mo-

bility or the impedance as it is either $+90^\circ$ or -90° corresponding to a positive slope ($+1$) or a negative slope (-1) respectively of the skeleton lines. The sudden shift of slope by a positive or negative value of 2 at antiresonances and resonances corresponds to phase shifts of 180° .

From this it can be concluded that the point impedances of Fig.11 have $+90^\circ$ phase below the antiresonance, -90° between the antiresonance and the resonance and again $+90^\circ$ above the resonance. The transfer impedances of Fig.12 have $+90^\circ$ phase below the resonance and -90° above the resonance as the slope of the curve changes by $+2$. For point and transfer mobilities similar rules are valid

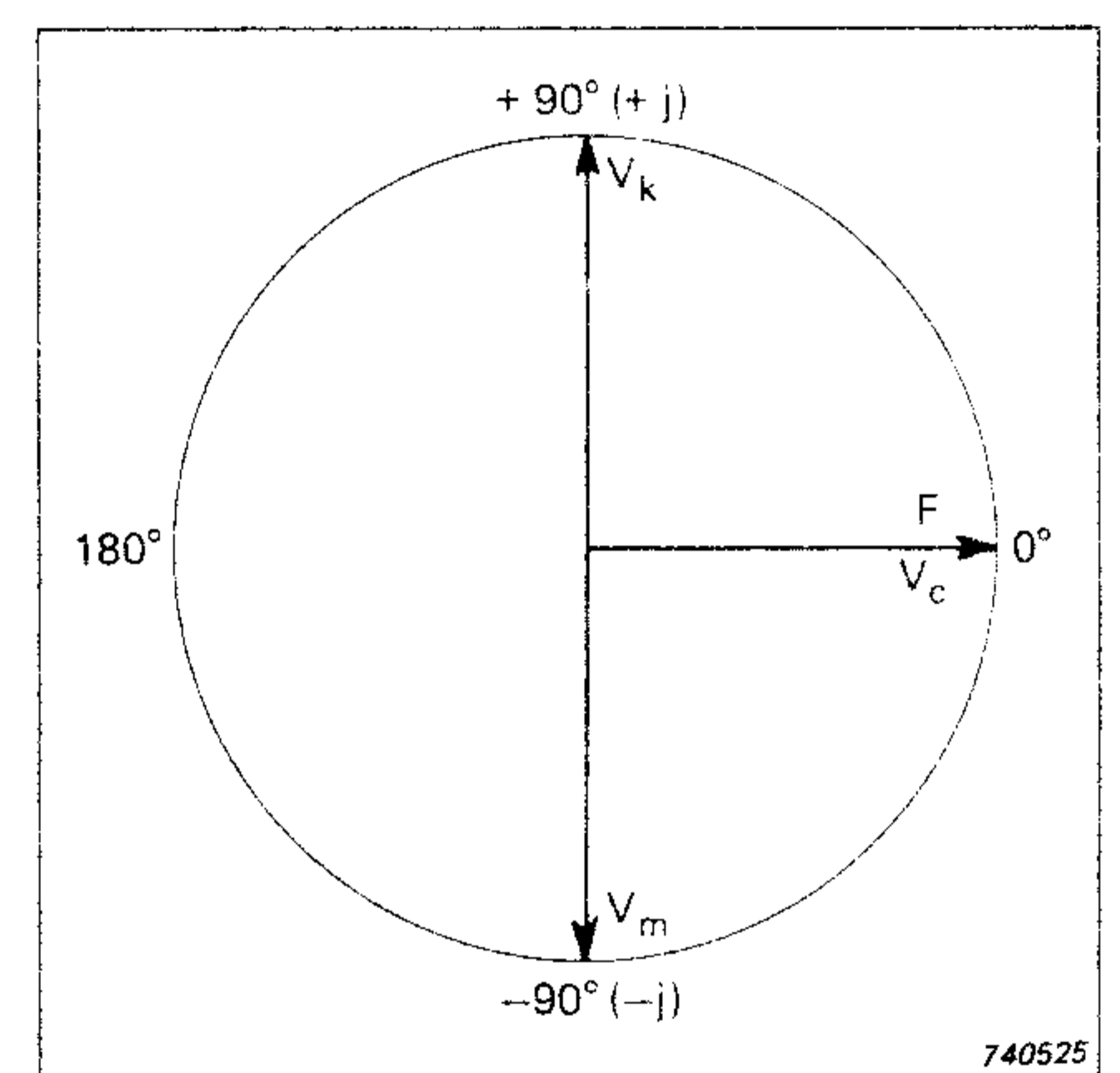

Fig.16. The phase relationships for single elements

i.e. as the mobility curve is changed by inversion, the phase changes from positive to negative or vice versa.

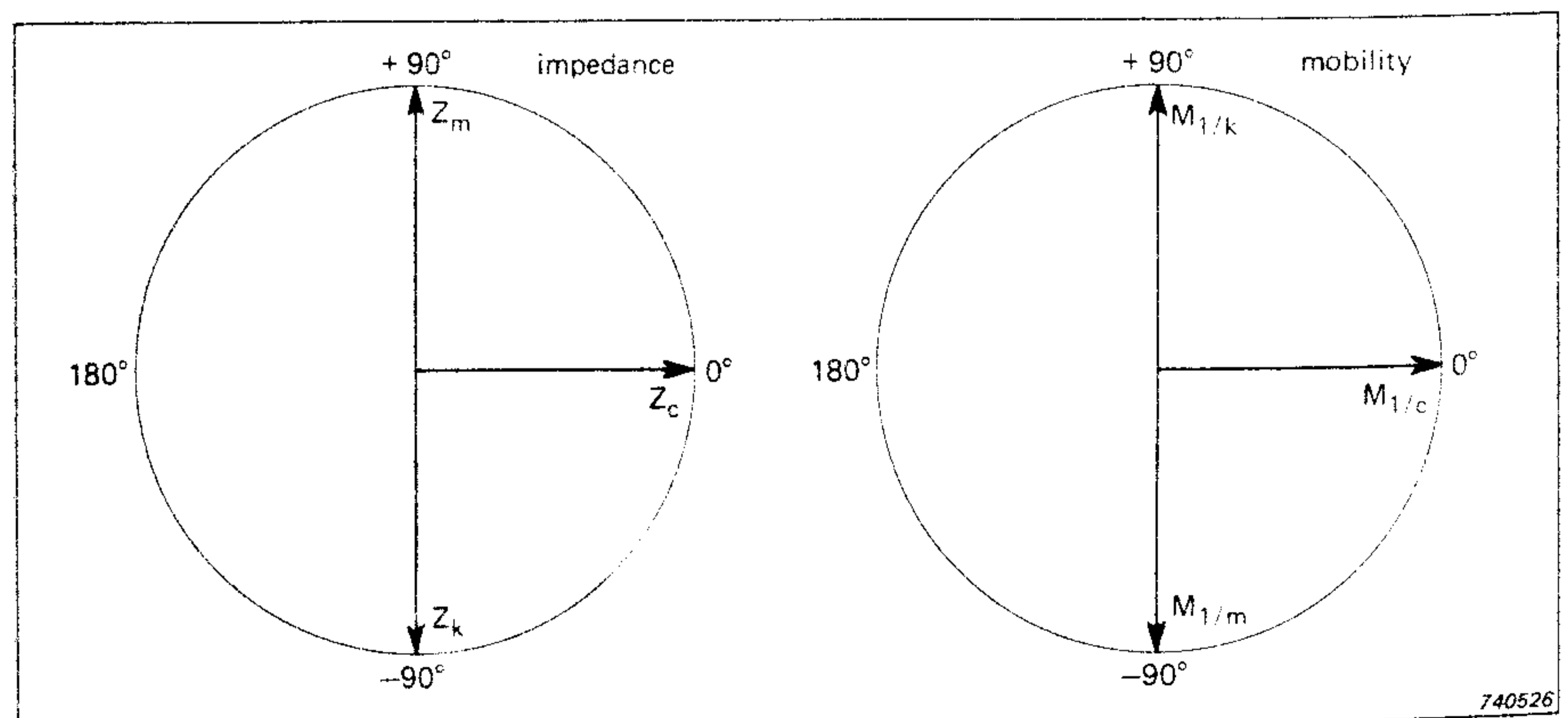

Fig.17. The phases of the impedances and mobilities of single elements

In the damped case the phase does not change immediately but varies gradually between $+90^\circ$ and -90° as the frequency is swept over an antiresonance or resonance, the direction of variation being dependent on which representation is chosen. For the point impedance and the point mobility the phase is zero at the resonance and the antiresonance, whereby these frequencies can be determined accurately by phase measurements even for highly damped structures.

The phase relationships are given by vector diagrams in Fig. 19 for an antiresonant system (Fig. 18) with $Q = 4$ at three frequencies. The system is equivalent to that of Fig. 6 with a damper added. As the damping is only evaluated around the antiresonance the most suitable damper configuration can be chosen. A

series damper, which provides a $Q = 4$ is therefore chosen to allow direct addition of the three mobilities. The response curve for the system is given by Fig. 13a.

It is seen that at $0,4 f_A$ the mobility of the mass is the largest at -90° . The $+90^\circ$ mobility is subtracted from the mass mobility and the remaining -90° mobility is added vectorially to the mobility of the damper (which is $0,25$) to obtain a resultant of app. 2 with a phase of $-82,4^\circ$.

At the antiresonance the -90° and $+90^\circ$ mobilities of the mass and the spring compensate each other exactly and the resulting mobility is that of the damper at 0° phase. At $2,5 f_A$ the spring mobility is the largest resulting in a positive phase angle of $82,4^\circ$.

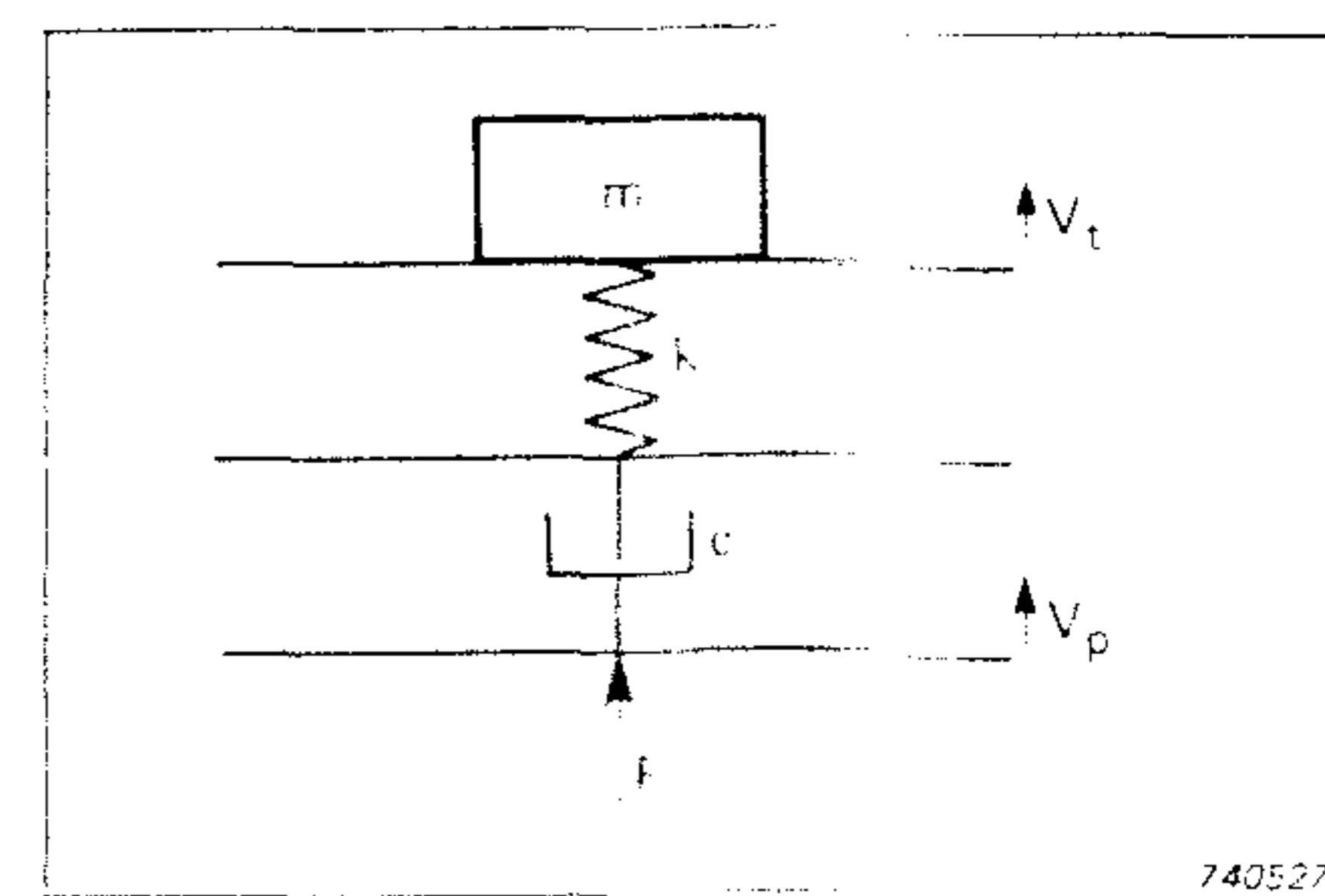

Fig. 18. Damped antiresonant system

For transfer impedances the phase angle may turn several times through 360° depending on the complexity of the system. The direction would be positive for positive changes in slope and negative for negative changes in slope (a change in slope of 2 being equal to a phase change of 180° and a change in slope of 1 being equal to 90° phase change).

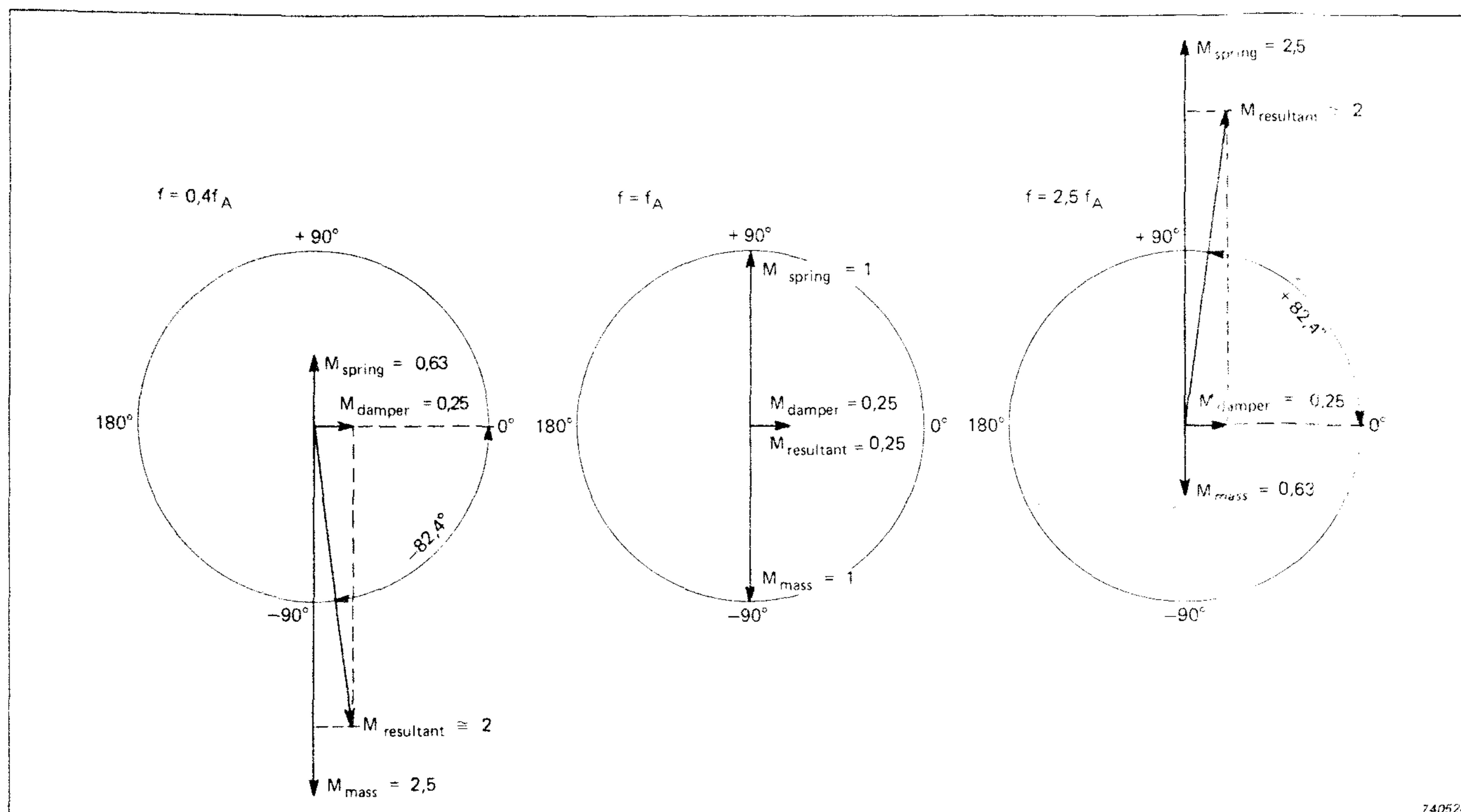

Fig. 19. The phase relationships around the antiresonance of Fig. 13a. See also Fig. 18 for the mathematical model

Practical considerations in the measurement and evaluation of mechanical impedance, mobility, and other ratios of force and motion

To measure mechanical impedance it is necessary to have a force source, force and motion transducers as well as analysing and recording equipment.

In Fig. 20 is shown an example of a measurement arrangement which provides the various functions which may be needed for most impedance or mobility measurements.

The arrangement was first used in the measurement of stiffness of asphalt bars to provide the complex modulus of asphalt at frequencies below the first bending resonance (Ref. 4).

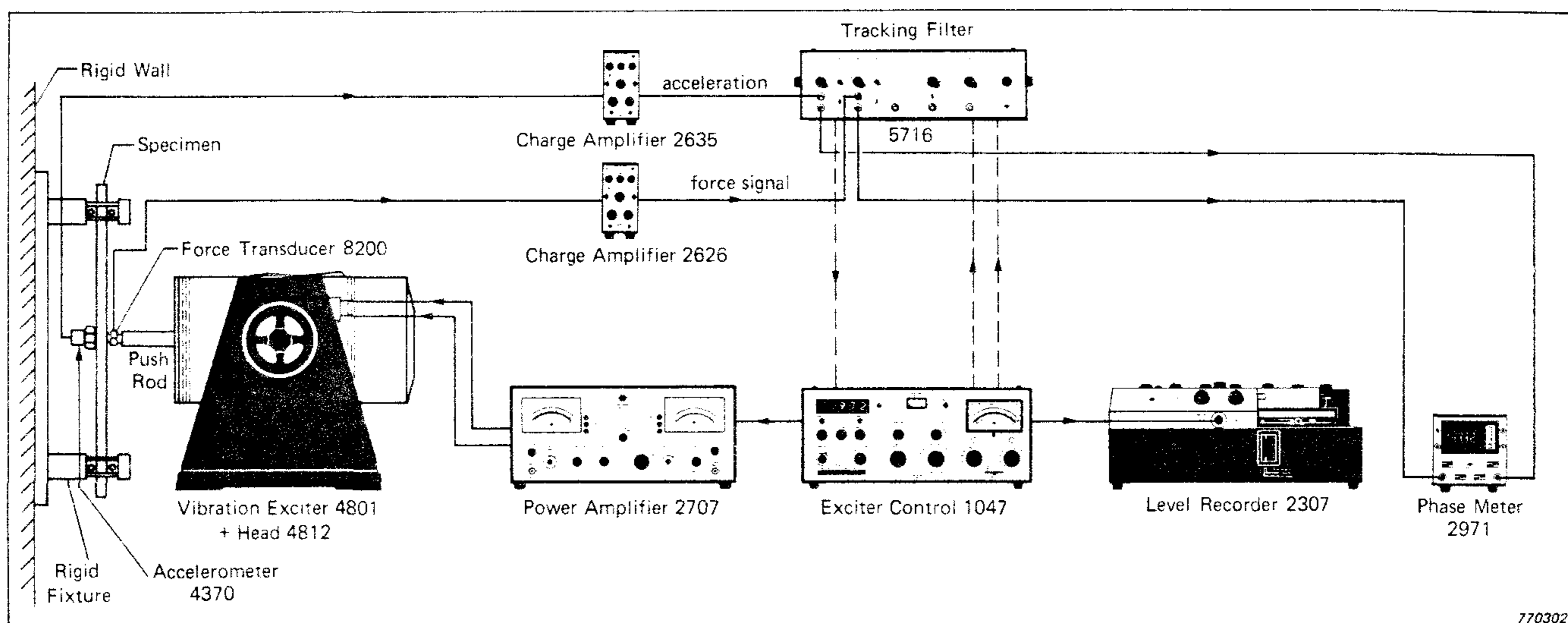

Fig. 20. Measurement arrangement for mechanical impedance measurements

This particular application demanded that the test specimen was excited with a constant displacement over the frequency range in question. However, the measurement arrangement is suitable for

any other of the ratios mentioned in Table 1.

Although the set-up shown may be used for a great number of applications it may sometimes be an advantage to use other instrumenta-

tion configurations from economical or technical reasons and it may be useful to examine each function of the system to find the demands and, thereby make the correct choice of instrumentation.

The Vibration Exciter and the Power Amplifier

The Vibration Exciter and the Power Amplifier should be considered as an inseparable pair. In certain circumstances, naturally, a larger Power Amplifier may be chosen to drive two or more Vibration Exciters in series or parallel from the same amplifier, or a Vibration Exciter may be driven by an inferior amplifier for non-demanding purposes. However, in most cases the Power Amplifier should be chosen according to the vibration exciter for example as given in Table 2 which shows the present range of Brüel & Kjær Vibration Exciters.

Vibration Exciter No.	Force N _{peak}	Stroke mm _{pp}	Velocity m/s peak	Max. Frequency kHz	Power Amplifier No.	Power VA
4801	380 - 445	12,7 - 25,4	1,01 - 1,27	5,4 - 10	2707	120
4802	1450 - 1780	19 - 38	1,27	4,5 - 5,5	2708	1200
4803	5340 - 6670	27,9 - 55,9	1,27	2,9 - 3,5	2709	6000
4809	44,5	8	1,65	20	2706	75
4810	7	6		18	2706	75

Table 2. Specifications for Vibration Exciters and Power Amplifiers

073040

The limiting parameter for the choice of Vibration Exciter is normally the max. force required. This is also the parameter of highest economic importance as it puts requirements on both the Vibration Exciter and the Power Amplifier. However, in some cases the max. stroke

desired is the more important parameter, and the interchangeability of Exciter Heads of the 4801, 4802 and 4803 family may provide the optimal solution of large stroke or max. force applied to the payload for any given size of Vibration Exciter (See Ref. 5).

The force and motion transducers

The demand to the force transducer is that it provides a true force signal to the preamplifiers in the force range required. For applications on very light structures below

1 kg mass the Impedance Head Type 8101 proves very useful as it combines a Force Transducer and an accelerometer with a relative polarity so that a Mass Compensation

Unit Type 5565 may be directly interconnected to compensate for the 1 gramme mass below the active elements of the Force Transducer if needed.

Type No.	8200	8201
Max. Tensile	1000 N	4000 N
Max. Compr.	5000 N	20,000 N
Charge Sens.	4 pC/N	4 pC/N
Resonant Freq. (5 g load)	35 kHz	20 kHz
Material	Stainless Steel	
Height	13 mm	36.8 mm

Table 3. Specifications for Force Transducers

For structures larger than app. 1 kg mass Force Transducers Types 8200 or 8201 should be used according to the force demands (see Table 3 and Ref. 6).

The motion is normally best measured by an Accelerometer. This is due to the large dynamic range, the large frequency range, and the reliability provided by these transducers. However, some consideration should be given to the choice of accelerometer type. For most non-demanding purposes al-

most any type of Brüel & Kjær accelerometer may be used although the range of Uni-Gain® types are preferred (charge sensitivity = 1 pC/ms⁻² or 10 pC/ms⁻² Types 4371, 4370 respectively, and voltage sensitivity 1 mV/ms⁻² Type 8301).

For application on very light structures, for very high levels of vibration and for high frequencies the range of Miniature Accelerometers Types 4344, 8307, or 8309 may be used to avoid loading the specimen and to ensure correct measurements.

For applications with low signal levels Type 8306 which has a sensitivity of 1 V/ms⁻² may be used. The latter accelerometer also provides stable operation down to 0.3 Hz.

Although all the accelerometers mentioned may be used down to 1 Hz extra care should be executed below app. 5 Hz especially at low signal levels. This is due to the fact that most piezoelectric transducers are sensitive to temperature transients which may be induced in the accelerometers by slight air movements in the room where measurements are taking place. To reduce this effect the accelerometers may be covered by insulating material or alternatively the above-mentioned Type 8306 or Quartz Accelerometer Type 8305 may be used.

The Quartz Accelerometer may be used down to virtually DC because of the stability of the quartz crystal. It may be screwed to the Force Transducer Type 8200 to form an Impedance Head if so desired.

Preamplifiers

As Accelerometers and Force Transducers have very high electrical output impedances, a preamplifier must be inserted after each transducer in order to provide a high input impedance to the transducer signal and a low output impedance to the following electronic instruments. Thereby low frequency and low noise operation is made possible.

Charge preamplifiers automatically compensate for change in sen-

sitivity due to different cable lengths.

Type 2634 is a small unit only 21 mm × 34.5 mm × 100 mm which can be placed near the measuring point, and which is operated from an external 28 V source. The Type 2651 is especially intended for use with Uni-Gain® charge calibrated accelerometers such as Types 4371 and 4370, and gives then a calibrated output proportional to acceleration or velocity.

For accelerometers with other sensitivities and Force Transducers, preamplifiers Types 2626, 2628 and 2650 provide both accurate sensitivity adjustment and adjustable gain. Type 2650 has 4 digit adjustment compared to 3 digits for the other two, and Type 2628 provides very low frequency operation to 10 Hz.

In addition, both Type 2626 and Type 2628 provide adjustable low pass and high pass filtering of the signal.

Exciter Control

The Exciter Control Type 1047 contains a fully electronically controlled oscillator section to drive the Power Amplifier in the frequency range from 5 Hz to 10 kHz. It contains one measurement and control channel, allowing two preset control values of acceleration, velocity

or displacement over the frequency range. It has no built-in filters but controls external filters and recording devices.

Similarly a number of other instruments may be used to obtain a controlled force or vibration level on

the specimen in question. The most obvious ones would be the Heterodyne Analyzer Type 2010 or perhaps the Sine Random Generator Type 1027. The former in addition gives excellent frequency analysis capability from 2 Hz to 200 kHz.

Recording Device

The Level Recorders Types 2306 or 2307 may be used with precalibrated recording paper as shown in Figs. 21 and 22. Recording papers can have a 50 mm, or a 100 mm ordinate (2307 only) which can be used for logarithmic scales of 10, 25, 50 or 75 dB according to the Recorder Potentiometer used (50 dB being the most usual) or for a linear scale (Potentiometer ZR 0002 for 2307) which must be used for phase recordings. The frequency scale of Fig. 21 has a decade length of 50 mm which provides the possibility of drawing the skeletons as described in the theoretical section. (The slopes being ± 20 dB for 1 decade or multiples of that).

To obtain better accuracy with closely spaced resonances or antiresonances the recordings can also be made with an enlarged frequency scale (either logarithmic or linear). For the latter a redrawing must be made to have log-log representation for final evaluation.

Similarly X-Y recorders may be used for recording of the graphs provided either the recorder output used (Heterodyne Analyzer Type 2010 or Measuring Amplifier Type 2607) has a logarithmic output, or the X-Y recorder has a logarithmic preamplifier.

If acceleration or displacement is measured or used for control instead of velocity the graph can be recalibrated to mobility or impedance by drawing a reference line on the log-log graph and reading the values above this line for each frequency. See Fig. 23.

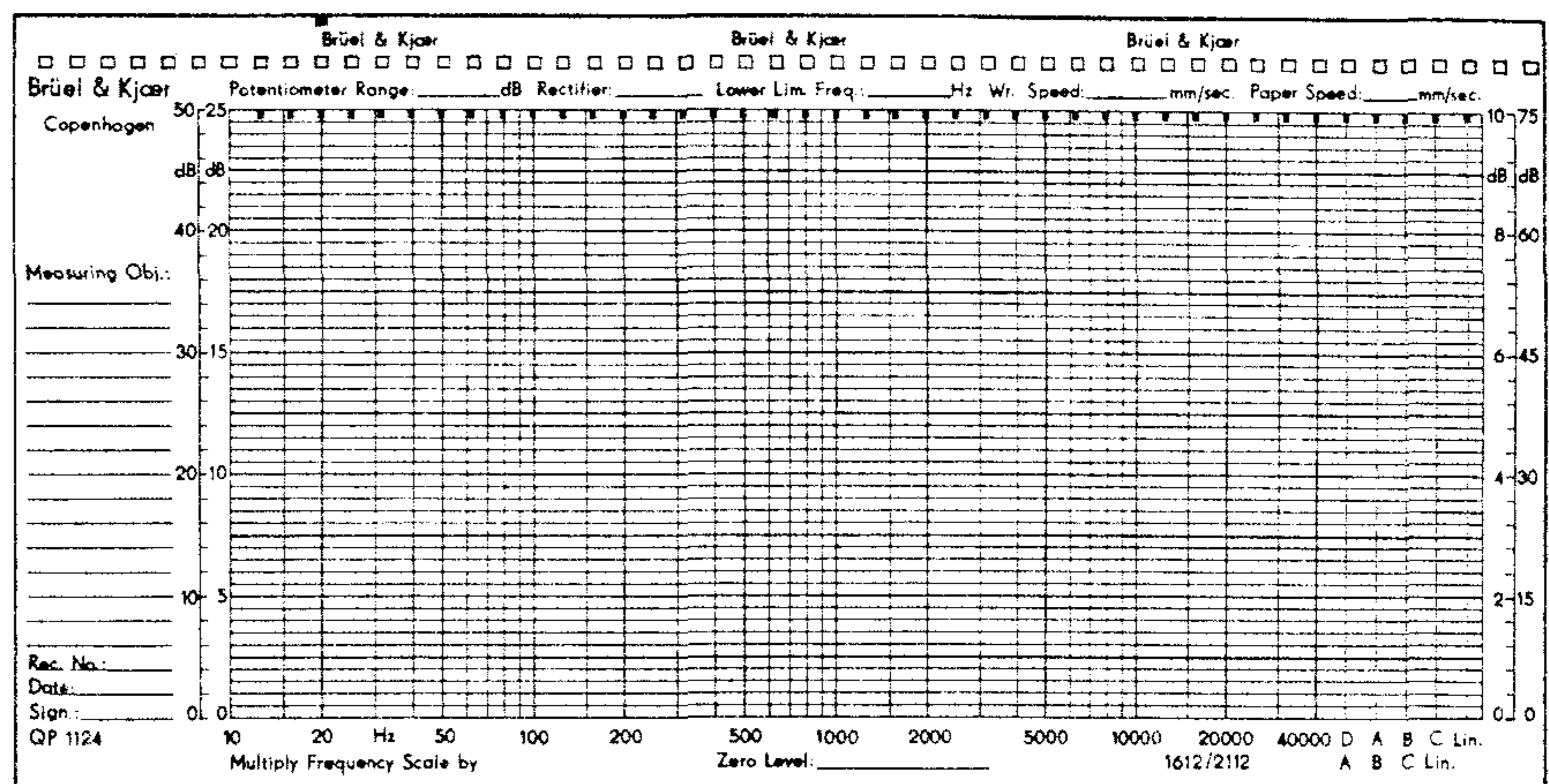

Fig. 21. Recording paper with precalibrated frequency scale and an ordinate calibrated in dB

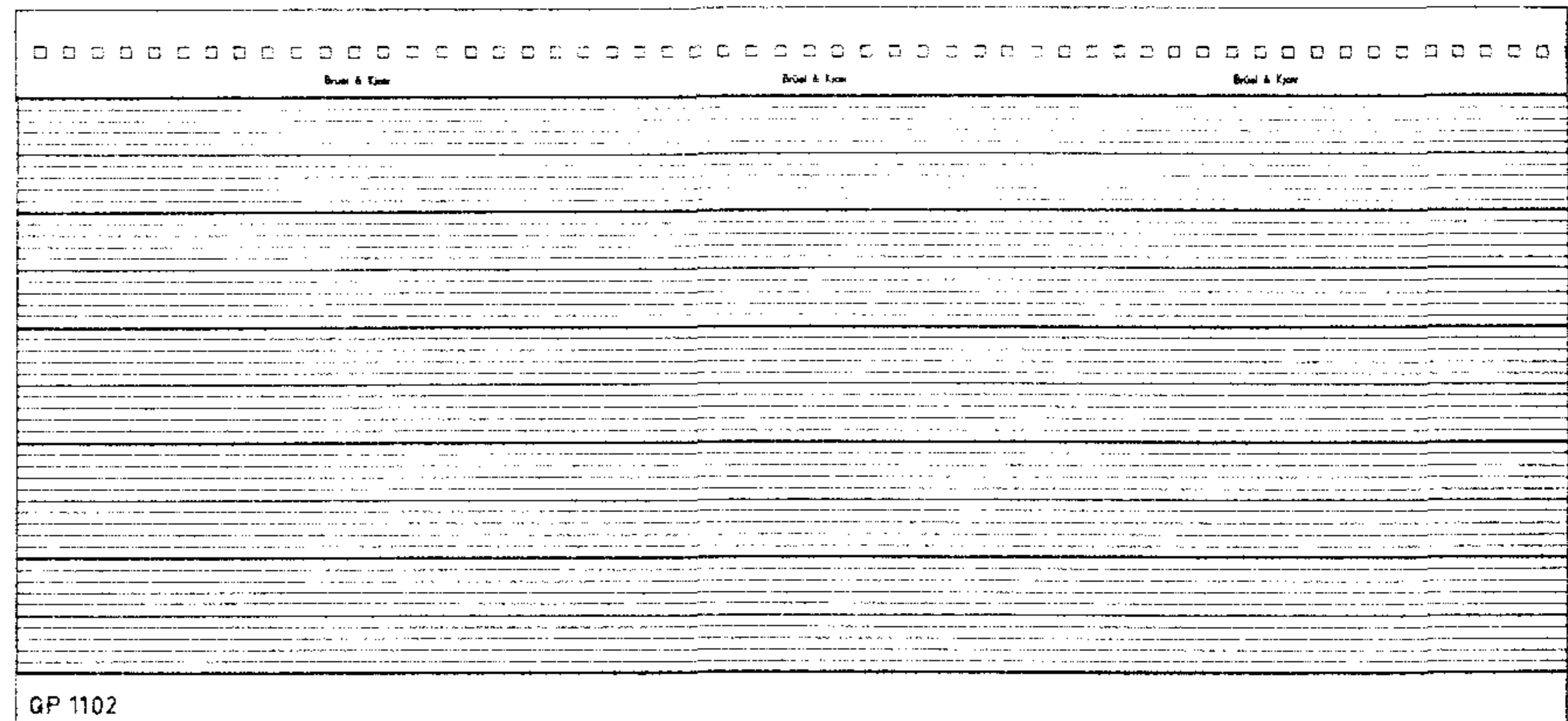

Fig. 22. Recording paper with calibrated ordinate

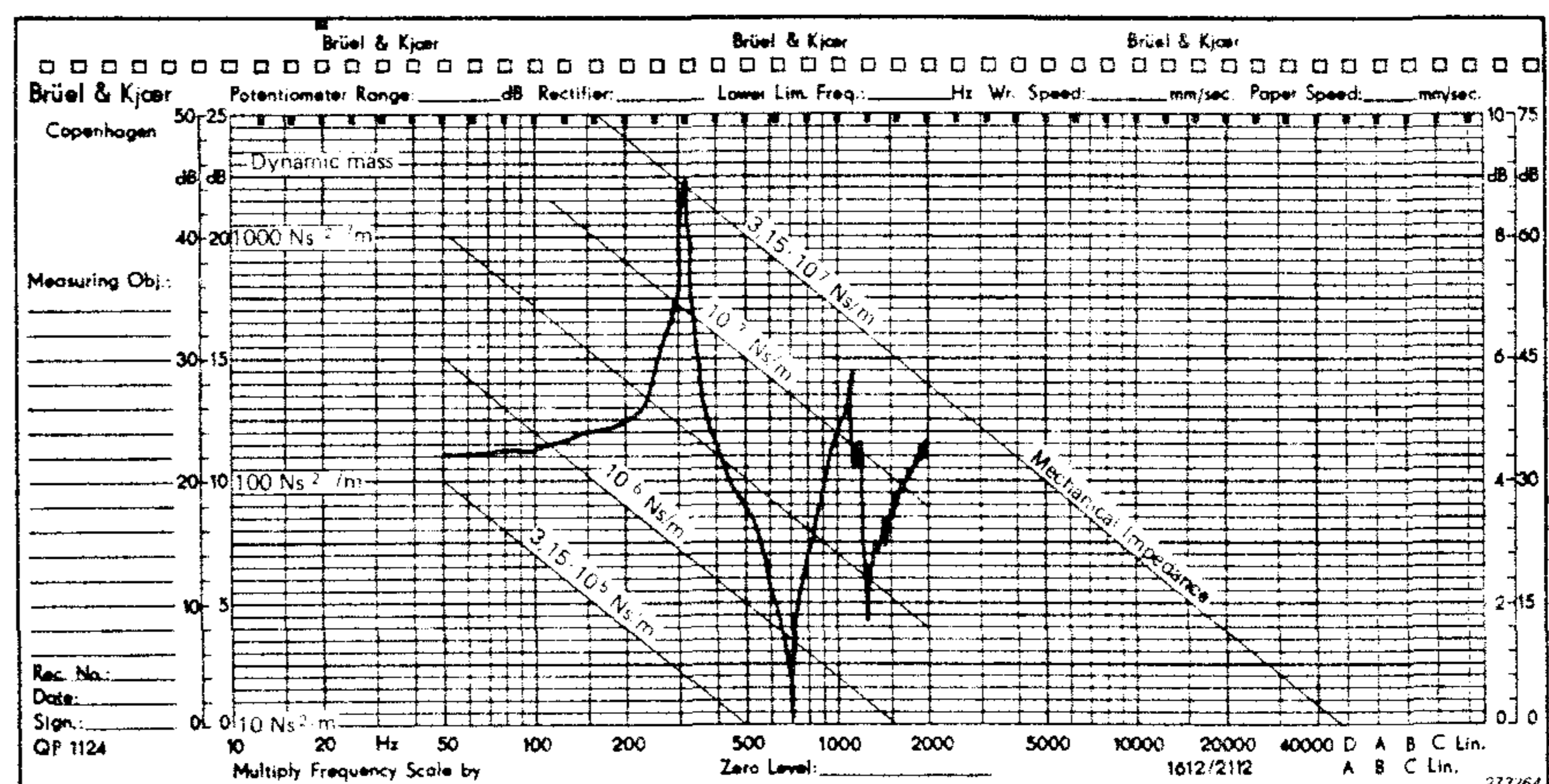
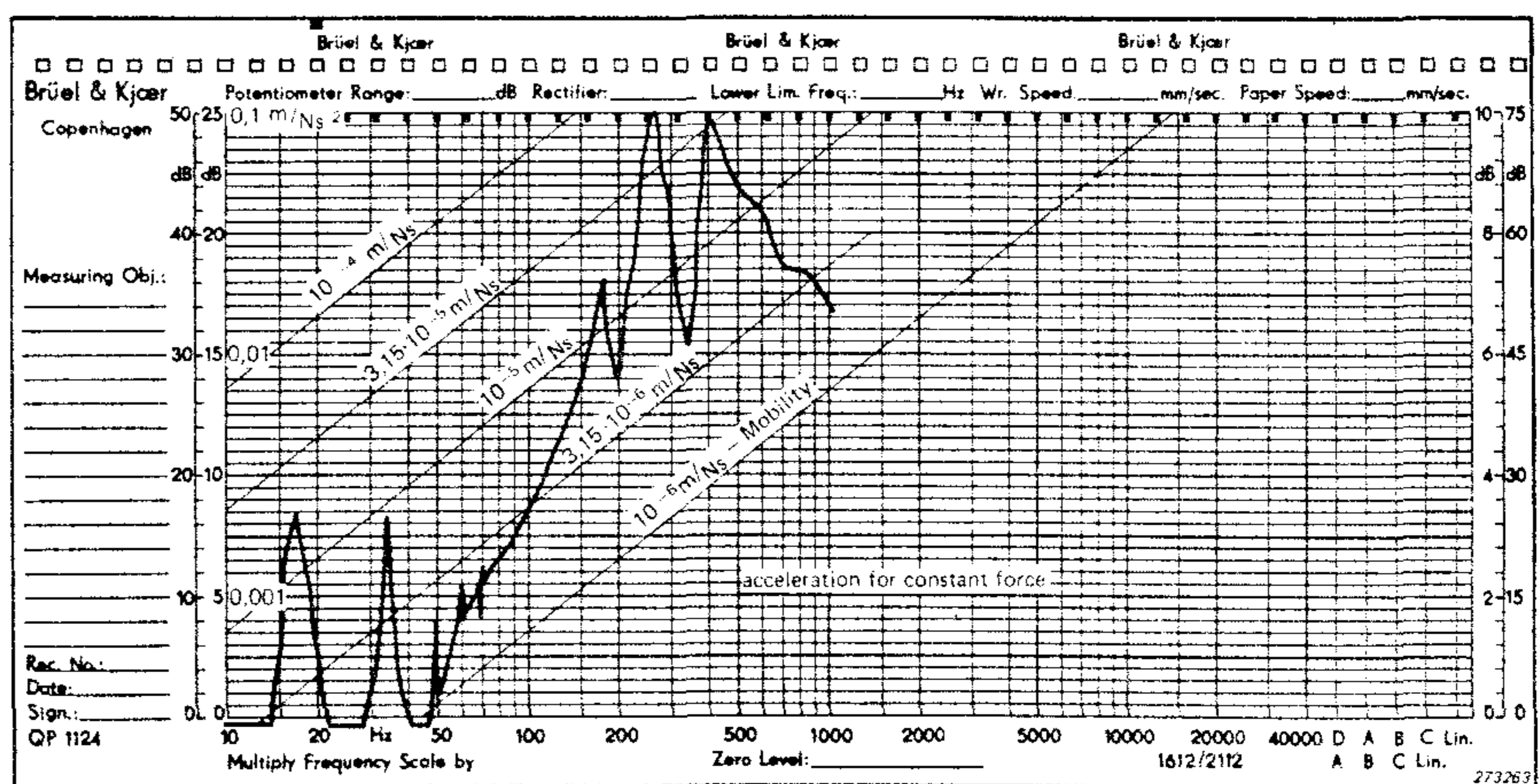

Fig. 23. Conversion of recorded curves to mobility and impedance curves

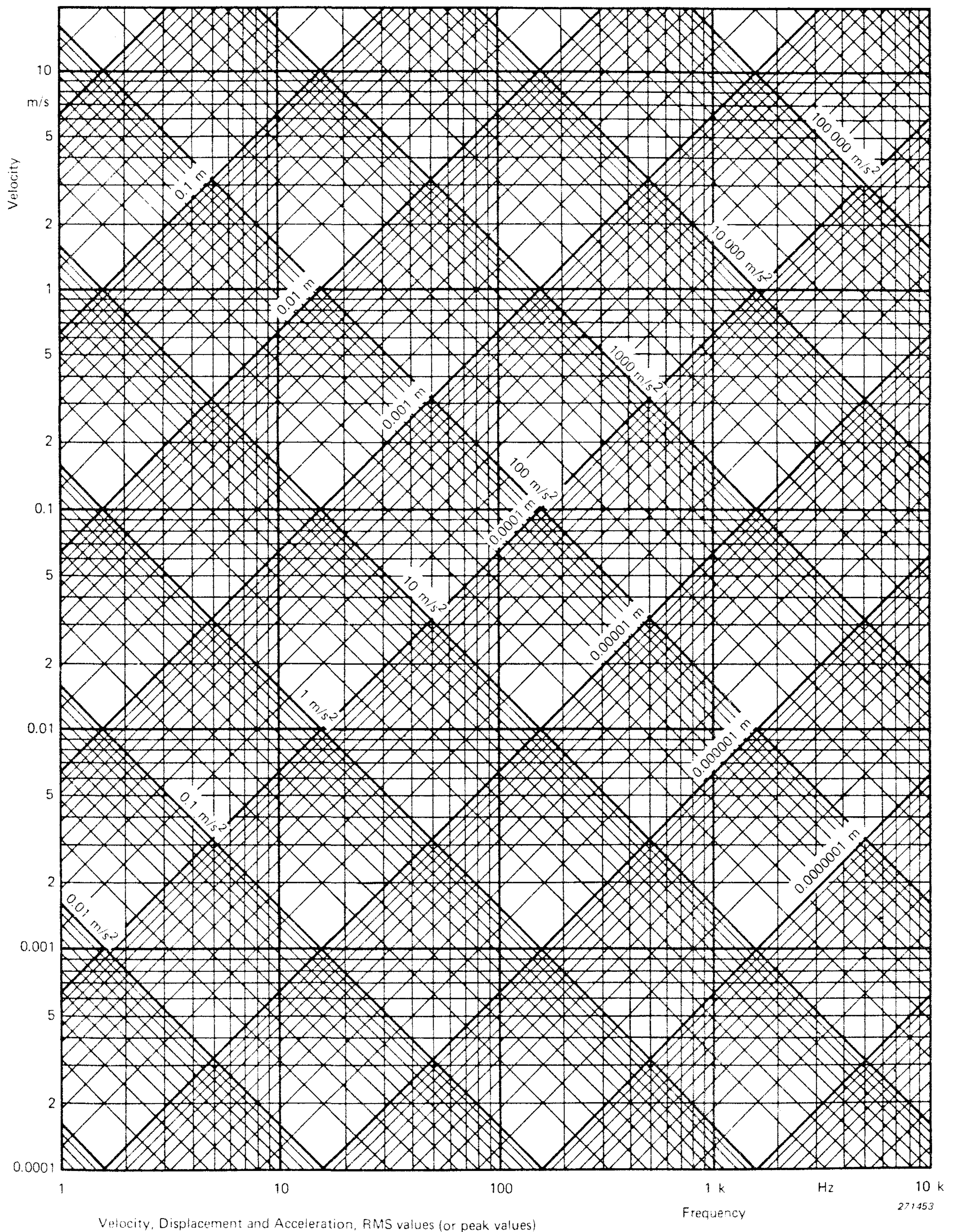

Fig.24. Nomograph of the relations of sinusoidal acceleration, velocity and displacement as functions of frequency

As acceleration for sinusoidal vibration $a = j\omega v$ the velocity is reduced for increasing frequency and lines with negative slope 20 dB/decade would represent constant mobility lines in the representation of Fig.23a. Similarly constant

impedance lines are given with positive slope 20 dB/decade in Fig.23b.

The curves are drawn through points at one frequency for which the mobility or impedance respectively have been determined from

the above relationship or from the graph in Fig.24.

When displacement has been measured the calibration is carried out in a similar way but with opposite signs for the slopes.

Phase measurements

The phase is best measured by means of a phase meter. For many purposes however, phase monitoring may be sufficiently well carried out by means of an oscilloscope on which either the beam is deflected in the X and Y direction by the two signals in question, or where one signal is displayed below the other.

In many cases, however the need for phase measurements does not arise. From good recordings of point impedances and transfer impedances it is possible to evaluate the response from the amplitude curves. However, when two systems are to be joined together and there is no large frequency separa-

tion between their resonances or antiresonances, it proves very useful to know the phases of the system responses. When the resonances or antiresonances of highly damped systems must be measured accurately, phase indication is vital. When the damping of a system must be determined outside resonance accurate phase measurement by a phase meter is absolutely necessary.

Under many other circumstances the phase measurements provide an extra check on the measurements. For example in measurement on complicated systems, the

acceleration or velocity at a given point may be the result of contributions from translatory motion and one or two torsional motions, and phase measurement with respect to force or to other points may be necessary to determine the mutual influence of these vibration modes. Similarly in mode studies on systems with varying stiffness the wavelength of vibration at a given frequency may vary considerably from one part of the system to another and phase measurements provide an extra control that all antinodes and nodes have been detected.

Examples of Application

In Fig.25 is shown an arrangement which was used to determine the point impedances of the surface of a hermetically sealed container for a refrigerator compressor (Fig.26). The purpose of the investigation was to find the optimal points to secure the springs in which the compressor was to be suspended, in order to reduce the transmission of vibration to a minimum and thereby to minimize the sound emitted from the container. The measurements revealed that at most points the impedance curve showed numerous resonances and antiresonances (see Fig.27a) whereas four points had relatively high impedance and very small variations over the entire frequency range (Fig.27b).

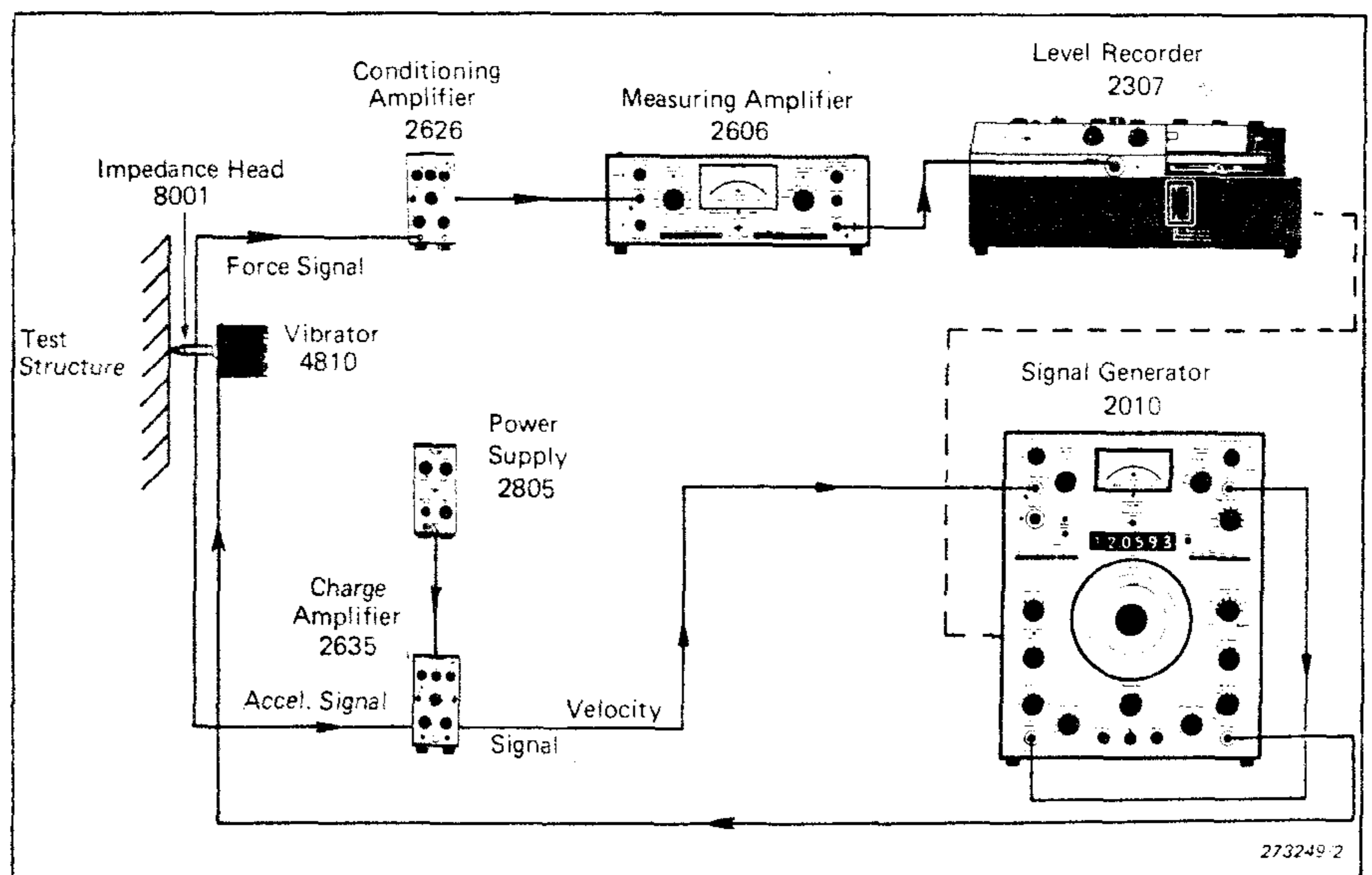

Fig.25. Measuring arrangement suitable to determine the point impedance at various points of the surface of a steel container for a refrigerator compressor

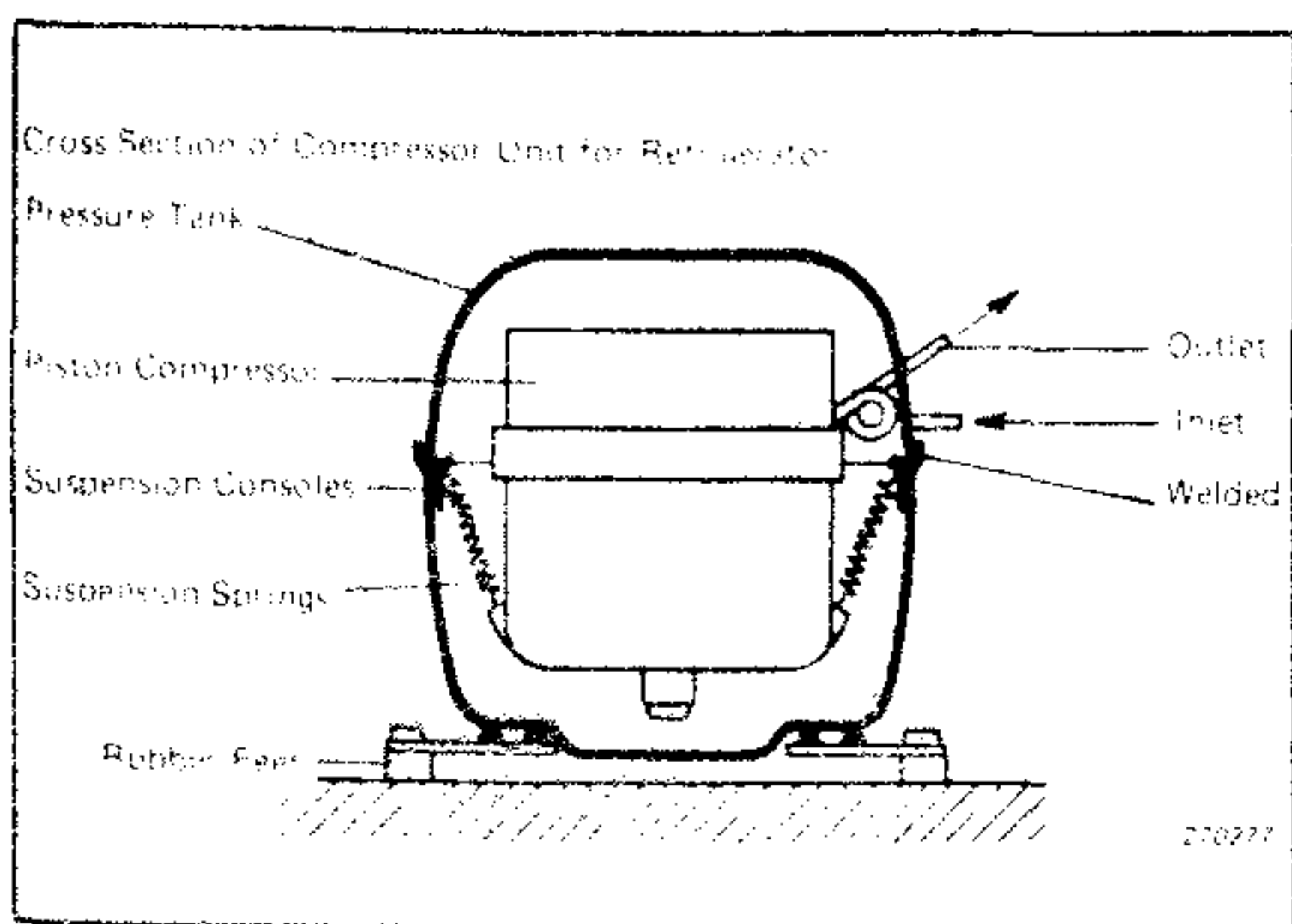

Fig. 26. Cross-section of a refrigerator compressor suspended in a hermetically sealed container

These nodal points would give minimum transmission of vibration energy when combined with the low impedance of the springs and were, therefore, selected as fixing points. (There would be a high transfer impedance from the compressor to the point; compare with the system of Fig. 6 and with the inverse of its mobility curve in Fig. 7).

Fig. 28 shows a very similar system used for the determination of

the modulus of elasticity of bars in longitudinal vibration. The bar is fixed onto the combination of a Force Transducer Type 8200 and a Standard Quartz accelerometer Type 8305 and the point impedance curve is obtained (Fig. 29). From the exact frequencies of resonance or antiresonance and the form of the curve the modulus of elasticity and the damping coefficient can be obtained (see Ref. 16). In Fig. 30 the antiresonant peaks have been enlarged by using a reduced paper speed and a 10 dB potentiometer.

In Fig. 31 is given an improved version of the instrumentation used for the measurements described in Ref. 7. The measurements were taken to obtain knowledge about the response of a prefabricated building structure by means of mobility measurements. The acceleration signal is integrated by the Conditioning Amplifier Type 2635 and led through the Tracking Filter Type 5716 to exclude ambient vibration from nearby punch presses. The mobility recording obtained is shown in Fig. 32.

Further examples of applications are given in the Brüel & Kjær Application Note No. 13-120 "Measurement of the Dynamic Properties of Materials and Structures" (Ref. 8).

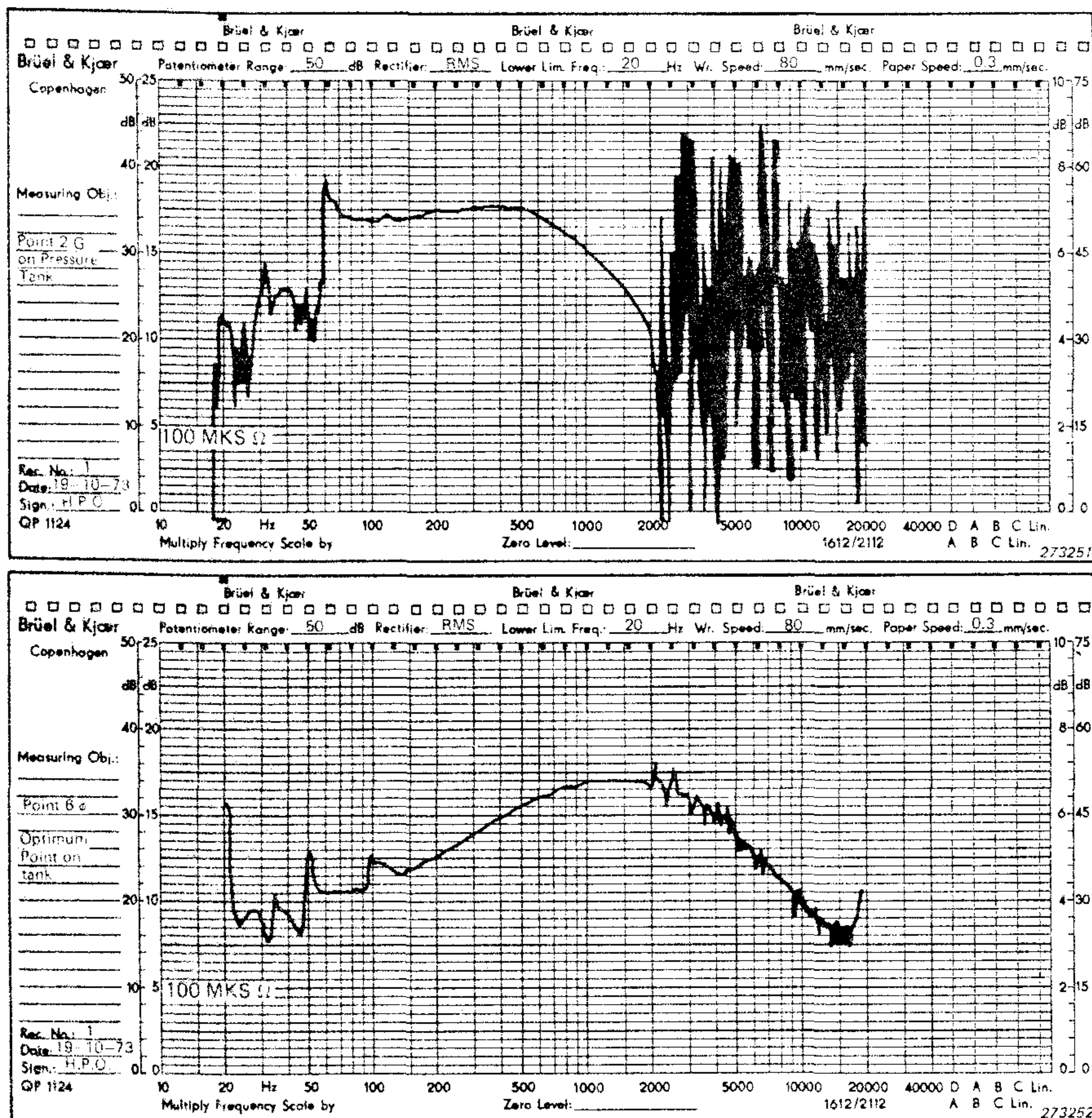

fig. 27. Point impedance recordings obtained from measurements on the steel container. a) as recorded at most points. b) as recorded in four points

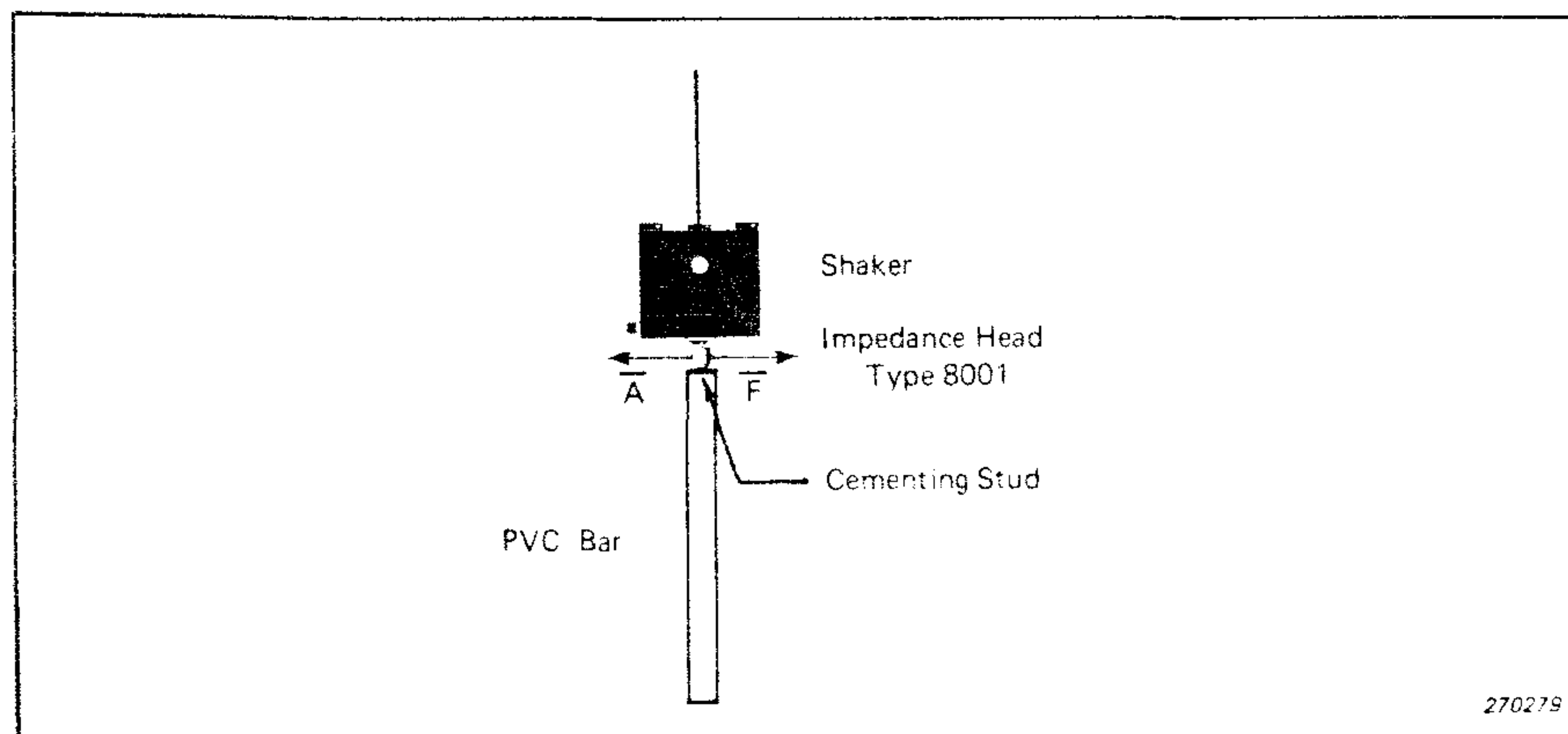

Fig. 28. Measurement configuration for determination of the modulus of elasticity of a PVC bar by impedance measurements

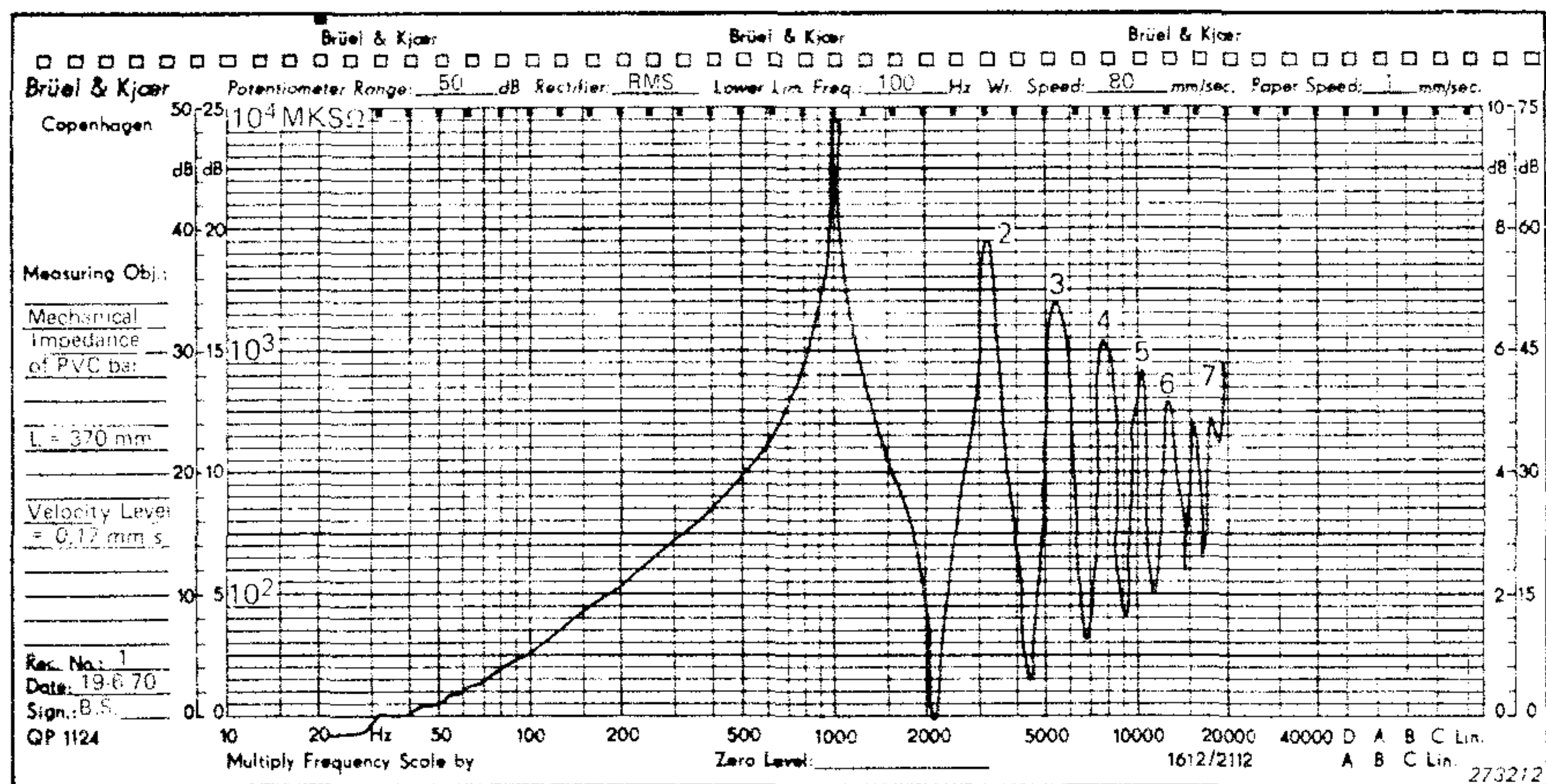

Fig. 29. The mechanical impedance recording obtained for a PVC bar

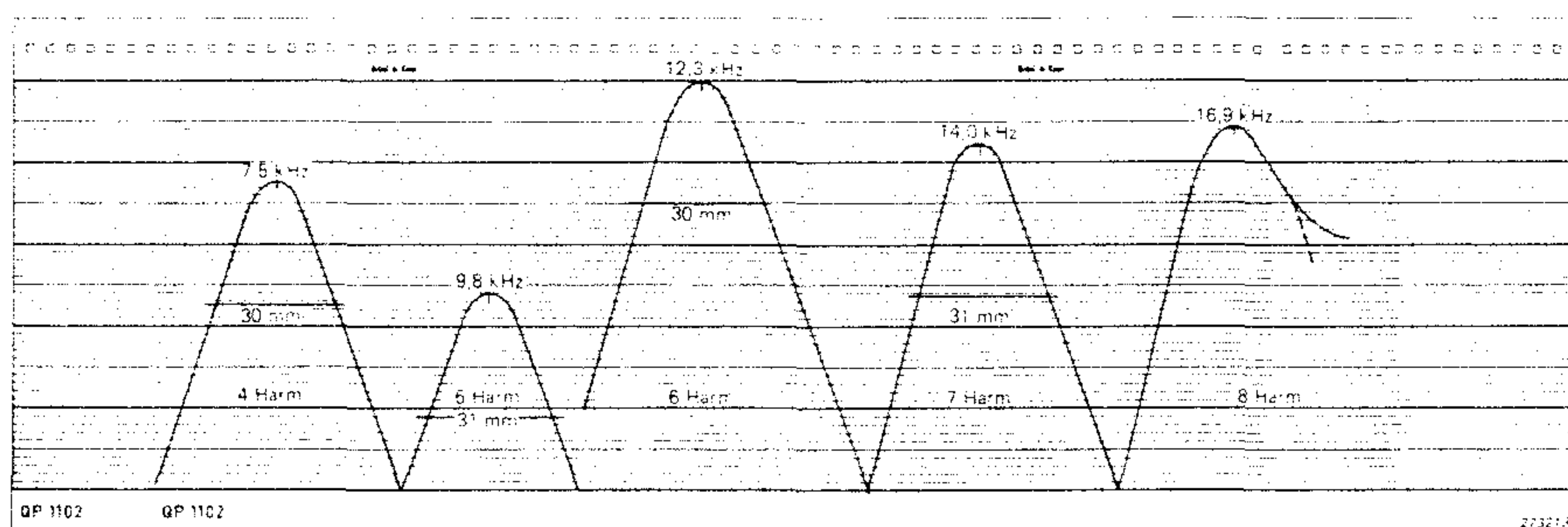

Fig. 30. Extended recordings of the antiresonant peaks of Fig. 29

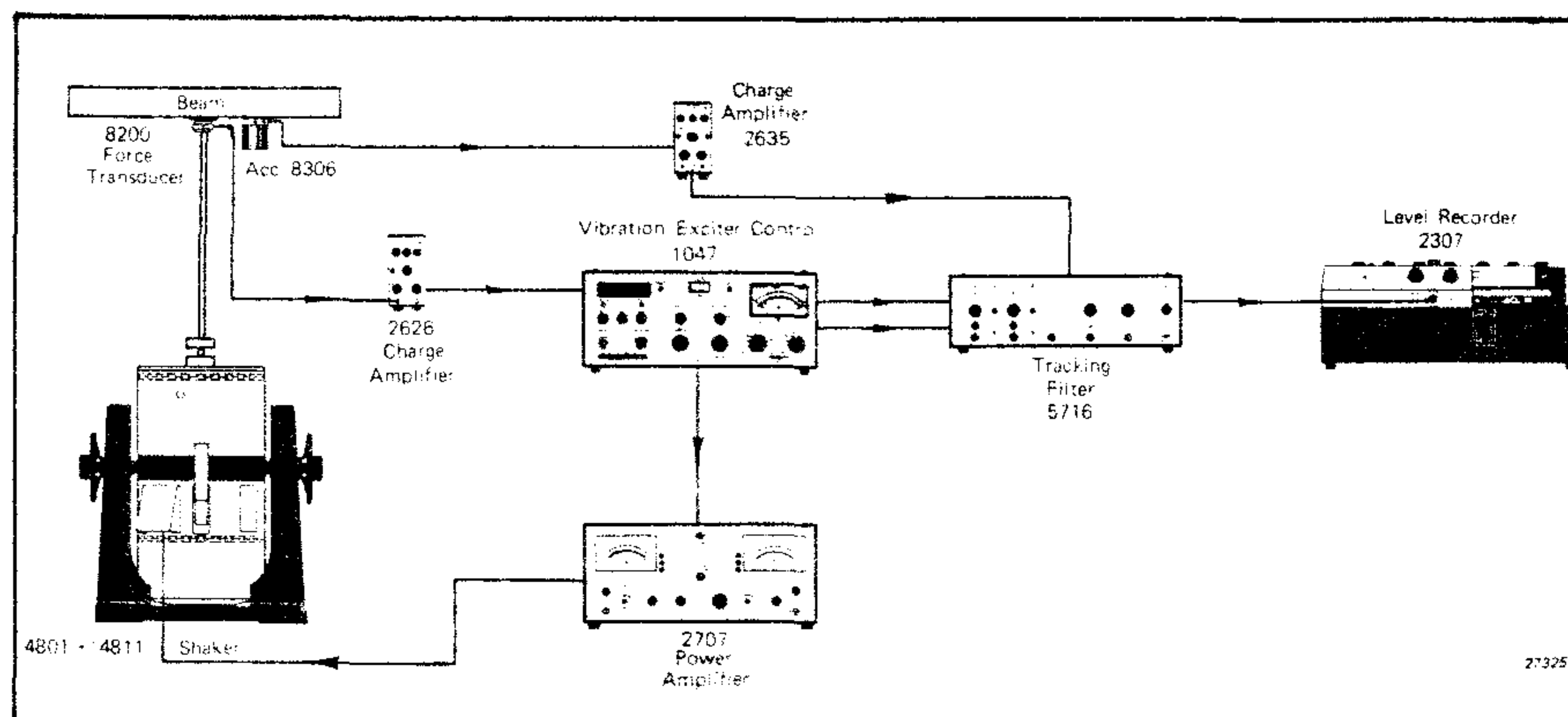

Fig. 31. Measurement arrangement for measurement of the mobility of a concrete beam

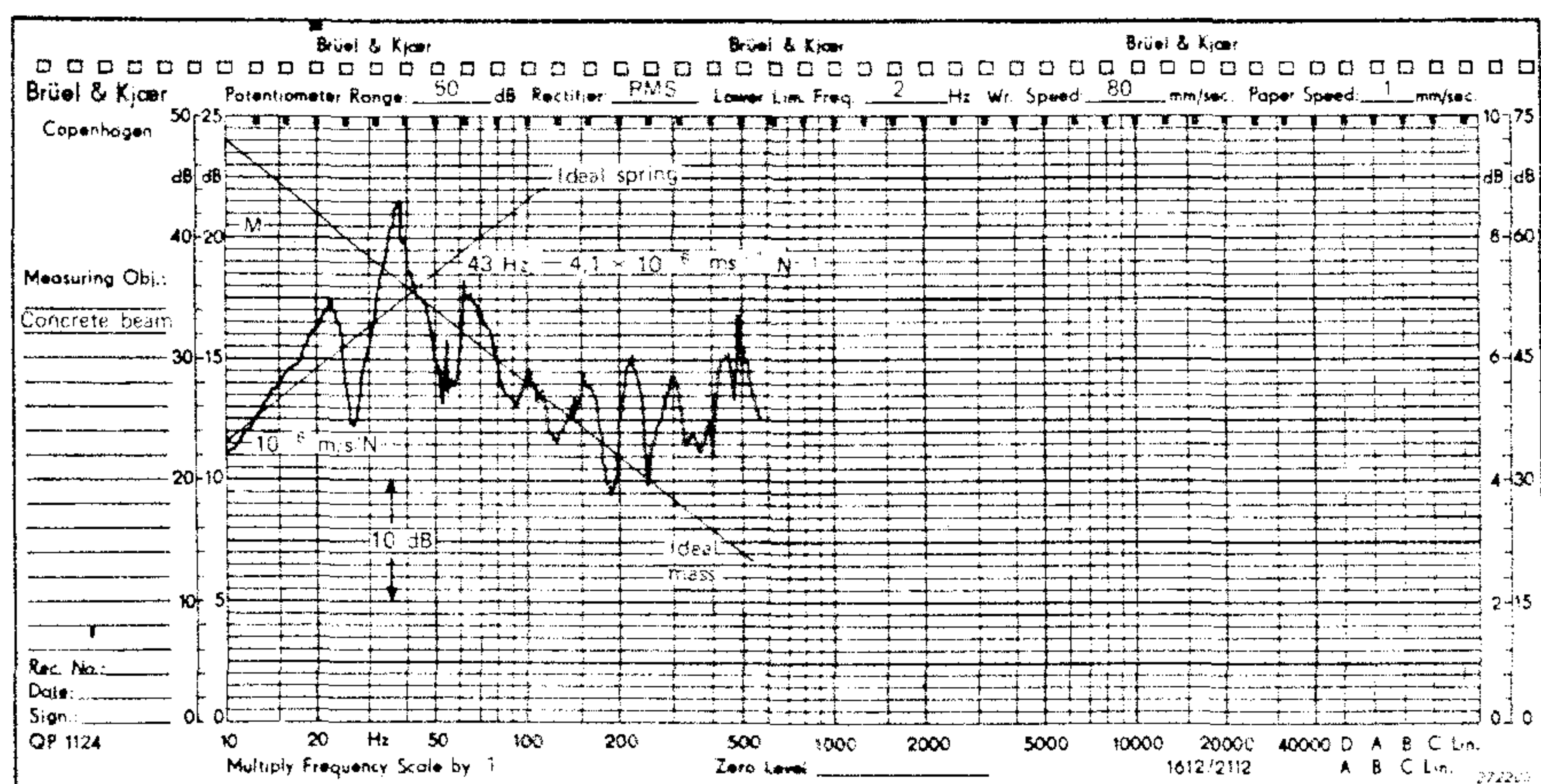

Fig. 32. Mobility recording obtained for a concrete beam

Concluding Remarks

Measurement of the mechanical impedance, mobility or any other of the complex dynamic ratios given in Table 1 may provide useful knowledge about a structure. By comparison of the obtained recordings with lines for masslike or springlike response one will gain insight into the dynamic characteristics of the structure to aid in further development or in corrective measures.

The existing forces may be derived by comparison with e.g., the mobility plot, and the need for correction may often be directly decided upon, by frequency analysis of signals generated during operation.

In more complicated applications the measurements may be used to find the elements of a model. Then comparison between calculated values for the model and measurement results may be used for correcting the parameters of the model until sufficient accuracy is obtained.

Similarly comparisons with frequency analyses may be used to calculate all relevant forces or couples in the system.

In other cases the response of subsystems may be measured and the properties of the total system be calculated before final assembly (See Ref. 12).

References

1. USAS S2.6-1963, "Specifying the Mechanical Impedance of Structures"
2. J.-P. Salter, "Steady State Vibration". Kenneth Mason 1969
3. Jens Trampe Broch, "Mechanical Vibration and Shock Measurements" Brüel & Kjær, 1972
4. K. Zaveri and H. P. Olesen, "Measurement of Elastic Modulus and Loss Factor of Asphalt". Brüel & Kjær Technical Review No. 4-1972
5. Galt Booth, "Interchangeable Head Vibration Exciters" Brüel & Kjær Technical Review No.2-1971
6. Willy Brænder, "High Frequency Response of Force Transducers". Brüel & Kjær Technical Review No. 3-1972
7. Torben Licht, "Measurement of Low Level Vibrations in Buildings" Brüel & Kjær Technical Review No. 3-1972
8. H. P. Olesen, "Measurement of the Dynamic Properties of Materials and Structures" Brüel & Kjær Application Note No. 17—180
9. C. M. Harris and C. E. Crede, "Shock and Vibration Handbook". McGraw-Hill 1961
10. D. J. Ewins, "Some whys and wherefores of impedance testing". See Dynamic Testing Symposium, Jan. 5—6, 71, London
11. R. B. Randall, "High Speed Narrow Band Analysis using the Digital Event Recorder Type 7502", Brüel & Kjær Technical Review No. 2, 1973
12. A. L. Klosterman, "A combined Experimental and Analytical Procedure for Improving Automotive System Dynamics". SAE, Automotive Engineering Congress, Detroit Mich., January 10—14, 1972
13. N. F. Hunter et al., "The measurement of Mechanical Impedance and its use in Vibration Testing". U.S. Nav. Res. Lab., Shock Vib. Bull. 42, Pt. 1, Jan. 1972, P.55—69
14. E. F. Ludwig et al., "Measurement and Application of Mechanical Impedance". U.S. Nav. Res. Lab., Shock Vib. Bull. 42 Pt. 1, Jan. 1972 P. 43—45
15. M. E. Szendrei et al., "Road Responses to Vibration Tests". Journal of the Soil Mechanics and Foundation Division, November, 1970
16. Measurement of the Complex Modulus of Elasticity: A Brief Survey. Brüel & Kjær Application Note No. 17—051
17. R. B. Randall, "Frequency Analysis" Brüel & Kjær, 1977