

# VIBRATION TEST APPLICATIONS

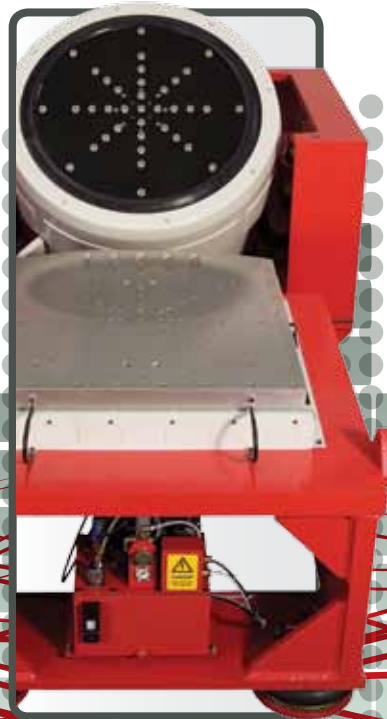

# COMPANY PRESENTATION

Brüel & Kjær is a world-leading manufacturer and supplier of sound and vibration solutions. We help our customers solve their sound and vibration problems, whether measuring traffic noise, car engine vibration, evaluating building acoustics or performing quality control. The wide range of business areas we cover gives us the capability to offer complete vibration testing solutions from a single supplier, providing our customers with a better platform and an expanded team to service their requirements.

In 2008, Brüel & Kjær acquired LDS Test and Measurement, making us the market leader in vibration test solutions. Brüel & Kjær's product range of transducers and data acquisition systems is perfectly complemented by the addition of the LDS product portfolio, which covers electro-dynamic shakers, vibration shakers, fixtures, amplifiers and vibration controllers.

## **COMPLETE VIBRATION TEST SOLUTIONS – WITHOUT COMPROMISE**

Brüel & Kjær can help you perform the most complex vibration tests, to ensure the integrity and reliability of your products. The comprehensive LDS range of electro-dynamic shakers is designed for vibration testing of devices of practically any size – from a semiconductor component to a complete satellite system.

## **ONLY ONE PC AND ONE SOFTWARE PACKAGE NEEDED**

With Brüel & Kjær your shaker, power amplifier, vibration controller and even environmental chamber are not only controlled from one PC – they run on one software package. Combined with our world-class data acquisition systems and analysis software suite, we offer a complete vibration testing solution.

Brüel & Kjær also offers vital service and staff training to maximise the operation of your vibration test system.

“Brüel & Kjær offers customers a single supplier for sound and vibration solutions, thanks to the combination of world-leading data acquisition hardware, analysis software, and the LDS shaker range. Thanks to over 50 years of experience with electro-dynamic shakers, we have the expertise to address virtually any vibration test scenario.”

Dr Lawrence Grasty, Vice President of  
Vibration Testing Solutions, Brüel & Kjær



# POWER SYSTEM TESTING

Honeywell Aerospace designed and developed the state-of-the-art Secondary Electrical Power Distribution System (SEPDS) for the Airbus A380. The A380 is the largest civilian air transport vehicle in production today, with two full passenger decks that can carry up to 853 passengers.

The SEPDS consists of solid-state devices that have the combined capacity to distribute up to 2000 channels of secondary electric power throughout the aircraft. As part of its development, the electric power system needed to be tested at extreme environmental conditions, to verify reliability and flight safety requirements. Honeywell Aerospace continues to be an innovative leader in electric power systems with an emphasis on flight safety and reliability.

The SEPDS for the Airbus A380 was manufactured in Toronto, Canada and was

subjected to vibration testing using the LDS V895 LPT1220.

Units are tested at ultra-low frequencies with high levels of vibration, in order to simulate worst-case inputs associated with a fan blade loss (windmilling) on the main engine of the A380. Simulating conditions such as these are a challenge for many test facilities.

Honeywell requested on-site assistance from Brüel & Kjær to make tests at levels and frequencies not normally achieved by an electromagnetic shaker system. Understanding the structure's mode shapes as well as the shaker's resonant conditions at frequencies as low as 3 Hz is essential to maintain proper levels.

Test equipment survival during the test was considered secondary to achieving these tests. Locking out the shaker's low frequency resonances and adjusting the

suspension/isolation systems for these conditions was done by Brüel & Kjær personnel. Careful monitoring during the test prevented damage to the shaker system for levels that exceeded the shaker system's designed specifications. Phase one involved using a multi-channel dynamic signal analyzer in parallel with the vibration controller to measure shaker movement, fixture movement and test article movement at reduced levels. Understanding these motions and adjusting the shaker system allowed Phase two testing with full levels and durations. Full level testing passed with no damage to the shaker system.

Performing testing in this manner saved Honeywell over \$400,000 in test equipment costs, as normally a much larger 'engineered' system would be used to perform this type of test.



Photos courtesy of Honeywell Aerospace, Canada



# AEROSPACE

The V994 Lin-E-Air is the most powerful vibrator in the LDS range, providing 289kN of sine force. Used for satellite testing, the custom design was specially tailored to meet the customer's particular requirements and to suit their existing LDS sliptables and guided head expanders.

The solid trunnion design enables testing from DC to 1700 Hz, achieving full

displacement at low frequencies for both horizontal and vertical testing.

Through site visits, our project team developed a layout solution incorporating modifications to standard ancillary equipment. Bespoke mounting plates were also provided to simplify installation onto the customer's existing seismic base and to suit their current equipment installation.



V994 Solid trunnion design enables testing down to DC

## | Accelerometer family



Brüel & Kjær has a wide range of accelerometers, suitable for many different applications

## | PULSE Modal Analysis



PULSE Reflex Modal Analysis is an easy-to-use post-processing application that enables users to perform single and poly-reference classical modal analysis even in the most demanding situations, by using a targeted set of best-in-class mode indicator functions, curve fitters and validation tools

# BALLISTICS TESTING

NAMMO AS is a leading developer and manufacturer of ammunition systems and missile & space propulsion products. The company has also become a world leader within environmentally friendly demilitarisation services. The Test Centre at Raufoss in Norway specialises in vibration and climatic (environmental) testing, and is capable of testing munitions for the defence industry, as well as providing these services for other industries such as automotive and space.

NAMMO has been using LDS shaker systems since the late 1970s when they purchased a V725 (6,667N / 1,500lbf) shaker. They have continuously added to their capabilities and now own a V964 (90kN / 20,000lbf) Combo system, a V994 (289kN / 65,000lbf) shaker, as well as an LDS vibration controller. These vibration systems are used with environmental chambers to provide reliability verification tests of various types of equipment. The equipment varies in size from ammunition boxes to rocket motors for missiles, through to antennae used on frigates that weigh up to 2.5 tonnes. Tests can run from 2 seconds to as long as 64 hours of continuous running, but durations of 1-4 hours per axis are more normal.

A major proportion of NAMMO's business is in the field of munitions testing. They have fifteen firing ranges of which the longest measures 2,000 metres. Longer ranges are available using the government's ranges. Various types of ammunition from 5.56 mm to 155 mm can be tested on these ranges. Live ammunition is tested to

verify its continued reliable operation. This starts with transportation testing with the munitions in their packaging. These tests involve vibrations and shocks to simulate transportation, as well as environmental testing to simulate storage. The two tests are also run together to show the combined effects. Increasingly, these tests are conducted using pre-recorded data taken from the actual transportation and operation of the systems. Once these tests are completed, the ammunition may be disassembled and inspected or fired on one of the ranges, to ensure it is still functional.

Safety is obviously paramount in this application. The tests are conducted in a blast-proof test chamber which is controlled from a separate protected room adjacent to the test room. The LDS Amplifier Remote Control unit proves invaluable as it allows the operators to control the amplifier from the safety of the control room. The test itself

is controlled using a LASER<sub>USB</sub><sup>TM</sup> controller. This complete remote control capability is unique to Brüel & Kjær, and is widely used in this kind of application around the world. Rocket motors are also tested using an LDS V994 shaker system. The motors can also be tested on the monorail sled for dynamic performance. The V994 shaker was originally purchased to conduct a specific test specification on a large test piece, however this has now enabled NAMMO AS to offer their services to a much broader commercial market than they previously thought possible.

Stain Halvorsen, Manager of the Environmental Test Facility, feels they now have a good range of test capabilities, and expects this to accommodate the payloads and frequencies they are anticipating from customers in the near future. Their efforts have moved on to improving the mounting and fixture designs to give more realistic

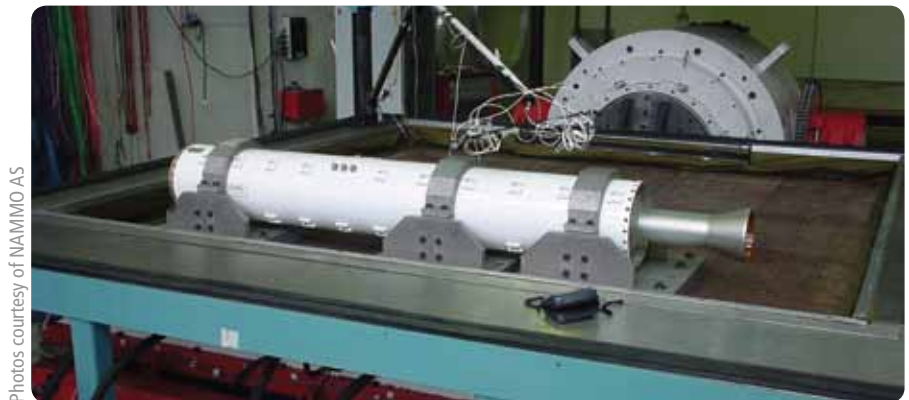

Photos courtesy of NAMMO AS

# DEFENCE



tests. NAMMO chose our shakers due to the technical knowledge and aftersales support we could offer locally, as well as the reputation of the range. The total system capability offered played a part in the decision. NAMMO now has a history of working with the LDS range of products that stretches back over 25 years.

Designed to test payloads for a defence customer, the Dual LDS V850-440 SPA24/56K special vibration test system has been engineered for coupled operation.

Each shaker is fitted with a guided head expander that allows interfacing to the customer's specialised payload. A steel truss rigidly connects the shakers together.

To ensure the dual system is mobile, each shaker base is integrated with Airglides, allowing the full shaker assembly to be moved – effectively on a cushion of air.

The special pneumatic control stands provide the operator with shaker body and armature position display and control. Shaker armature and body position are

automatically controlled to ensure that the complete system remains balanced.

Both shakers can be used either individually or in the standard dual (push-push) configuration, thanks to the LDS Multiple Amplifier Control (MAC) system. Each shaker is driven at a tight amplitude and phase tolerance to the other, to ensure consistent application of vibration, minimise cross-coupling and ensure system and payload safety.



Dual V850-440 mounted in solid trunnions with load bearing platform

# SATELLITE TESTING

The space industry probably has the most demanding requirements of vibration testing anywhere in the world. Given the huge stresses involved in the launch of a payload and the fact that you cannot easily repair a damaged system or satellite once it has been deployed, it's best that the system has been thoroughly tested before launch!

The European Space Research and Technology Centre (ESTEC) invested in a quad shaker system using LDS V984LS shakers, delivering up to 640 kN of sine force (each shaker is capable of delivering a maximum sine force of 160 kN/36000 lbf). The four shakers are mounted on a seismic block and connected to a head expander level with the floor. This is used to test satellite solar arrays, large satellite communications antennae, and complete satellites from 400 kg (882 lb) up to 10,000 kg (22,046 lb). These satellites are launched using a variety of rockets including ARIANES and SOYOUZ.

The vibration systems are used for a variety of tests. Alexandre Popovitch, Head of Test Facilities and Test Methods at ESTEC, commented: "For large, light specimens, sine and random tests are usually performed at levels up to 20 g. This will require almost 100% of the quad shaker system's capabilities. Complete satellites are only submitted to sine vibration at acceleration level close to 1 g. In certain cases, the whole satellite can be submitted to high acceleration levels to simulate the static loads." A test can take anything from one day to two weeks to set up, depending

on the number of sensors to be mounted, with the actual tests lasting a few minutes at a time.

The quad system is a vital component in ensuring that ESTEC and the European Space Agency (ESA) maintain their position at the forefront of the space industry. "This new facility will save time in the critical path of the mechanical test campaign, and therefore, will reduce the testing price for our programme," said Mr. Popovitch.

## EUROPEAN SPACE RESEARCH AND TECHNOLOGY CENTRE – ESTEC

ESTEC is the technical heart of ESA, and is located in Noordwijk in the Netherlands. The agency manages nearly all the programme's space projects, covering missions on science, human spaceflight, telecommunications, satellite navigation and earth observation. The only exception is the actual launchers used to deliver the payloads into orbit, which are managed by Arianespace in France. Overall, over 12,000 personnel in over 100 European companies are involved in the preparation and launch of each space flight.

ESTEC Test Centre is home to about 60 personnel who cover all the fields required for the qualification of space hardware for thermal, electrical and mechanical environments. The mechanical facility is operated by six personnel who control the vibration test systems, acoustic chamber and mass properties measurements systems. This facility is the largest in Europe and one of the biggest in the world.

## LDS V984LS SHAKER SYSTEM

Paul Steel, Project Manager for the vibration system, is justifiably proud of its contribution to the overall installation, and the success he and his team have achieved. He describes this new system as "a showpiece for the industry." He went on to say: "This has been a big project in partnership with other suppliers and we have all pulled together to see the project through to a successful conclusion."

This new quad-shaker system adds to an existing dual-V984LS system, which can either be used in single-shaker mode (vertical or horizontal with a sliptable) or in dual-mode with a custom-made dual head expander. The sliptable for horizontal excitation measures 3.5 m (11.48 ft) long by 3.0 m (9.84 ft) wide. The dual system is fixed to a spring-mounted 550-tonne seismic mass to protect the building from the forces generated.

ESTEC also has a V964LS (90 kN/20,000 lbf) shaker used for testing smaller payloads in sine, random and shock modes up to 2,000 Hz, and with a 1,200 (3.94 ft) × 1,200 (3.94 ft) mm sliptable for horizontal testing.

## THE ADVANTAGE OF WATER-COOLED SHAKERS

The V900 series of water-cooled shakers has a long-established reputation in the aerospace and space industries. Water-cooled shakers are able to deliver higher forces than equivalently powered air-cooled shakers. The water-cooling is applied to the field coils and results in quieter operation



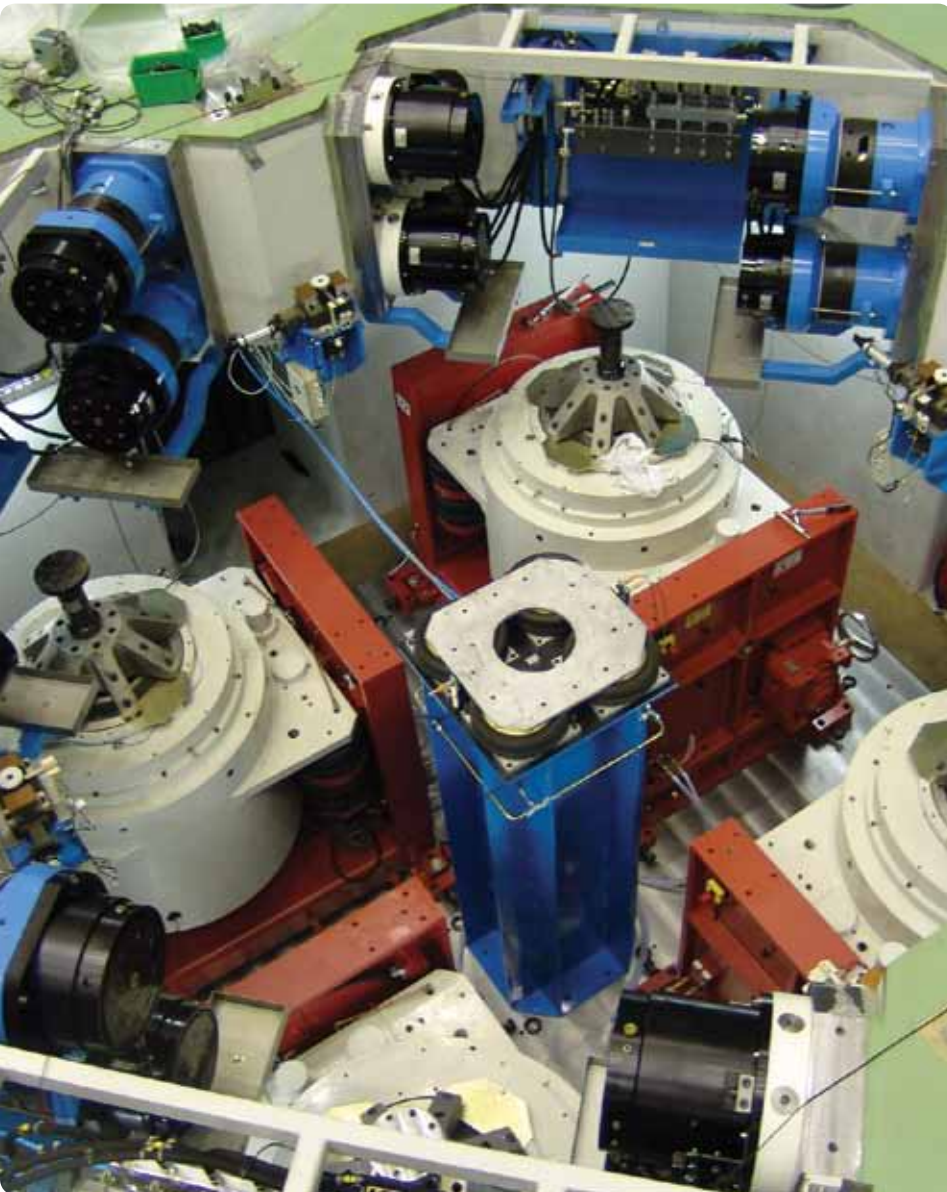

Photo courtesy of ESA/ESTEC

and a cooler body temperature, minimising the temperature effects on the equipment under test. This makes water-cooled shakers ideal for applications requiring high forces or large payloads being tested for short durations. The absence of air blowing around the shaker and test equipment makes water-cooled shakers particularly appealing in cleanroom environments, or when testing hazardous materials.

Acknowledgements: Brüel & Kjær would like to thank Alexandre Popovitch, Head of Test Facilities and Test Methods, ESA/ESTEC Test Centre Division, and Gaetan Piret, Technical Officer in charge of the quad shaker system's procurement, for their contributions and permissions for this article.

## Highly attuned accelerometers



Type 4524 series consists of lightweight triaxial piezoelectric OrthoShear® accelerometers, each with three independent outputs for simultaneous measurements in three mutually perpendicular directions. Type 4524 series utilises a 4-pin connector.

# HOT SHAKE

## VIBRATION TESTING AT TEMPERATURES UP TO 1,000 °C

Cars are a hot topic around the world – and not only when it comes to racing. Even normal cars can get very hot – especially components like the exhaust or the brakes. Such extreme conditions are simulated during design to ensure that these components do not fail when it counts.

Vibration testing experts simply call it 'Hot Shake', – but it is not that simple! At Peus Testing in Germany they are pushing the envelope of high-temperature environmental testing. The combination of a 'hot gas generator' and a shaker system creates a very hot test environment. Gas at temperatures of up to 1,000 °C streams through car components such as catalysts or diesel particle filters, causing them to glow bright red.

In order to improve the thermal stability of components, it is necessary to push the limits during the test. Air volume of up to 700 kg mass per hour streams through the device under test and generates a pressure of up to 3 bar inside. Under these conditions, the stainless steel becomes more homogeneous and the component



approaches a point at which it expands like a balloon.

As tough as this might already be, the design engineers want to know the full truth, so when the thermal limits are reached the test engineer switches to the next level. From his cool position in the control room, he starts his 60 kN shaker system with the click of a mouse. This shaker system consists of a V8 Shaker, a LASER<sub>USB</sub> Vibration Controller and an SPA-K Power Amplifier. The vibration controller ensures that the component is vibrated constantly at 175 Hz, and during this test – which runs for more than 100 hours non-stop – the device experiences acceleration up to 75 gn peak. Given the fact that this happens at its thermal limit, one would think this should be enough to prove the product.

But the test has not yet reached its climax. A full 15 minutes after the test run begins, the controller opens a valve for a new experience: thermal shock! Here, 20 litres of cold water at 13 °C rain onto the red-hot device. The conditions for the material test are thus changed in a split second to that of a worst-case scenario. Shocked by the flood of cold water, the material rapidly contracts, changing the stresses on the component.

The cold water shock treatment ends after 30 seconds and terminates the first test cycle. But this is not the end – it is only the beginning. In total, 499 more cycles follow before the test is complete. Only after more than 100 intense hours of testing on the hot shake test bench can the design engineers be certain that their component is ready to face the real world.



Photos courtesy of PEUS, Germany

# ELECTRIC & HYBRID TESTING

## BATTERY PRE-PRODUCTION QUALIFICATION AND FUNCTIONAL TESTING FOR ELECTRIC AND HYBRID VEHICLES

As the automotive industry embraces hybrid powertrains, there is an increased demand to invest in the research and development of battery power.

Competition in the automotive industry and the speed of development in hybrid power technology is driving manufacturers to deliver high quality products in shorter timescales. Time to market is key and has put an emphasis on product testing; vehicle re-calls are expensive. Manufacturers are therefore under increased pressure to perform accelerated lifetime vibration testing, even on large and fully operational component assemblies, whilst also meeting all of their health and safety guidelines.

## HYBRID BATTERY DURABILITY TESTING

Working with a leading automotive research department, we have delivered a custom vibration test system for hybrid battery durability testing and for Highly Accelerated Life Testing (HALT) of multi-cell computer-managed batteries. The system will be used for hybrid vehicle pre-production qualification, and for the functional testing of a complete battery assembly designed to be mounted underneath a car.

This vibration test system is a good example of a customer requesting a high-performing and versatile system that can easily be adapted to several test demands

on large heavy payloads, in multiple axes. The requirements demanded a heavy-duty system that could perform accelerated durability tests simulating the whole lifetime of the car.

The V8 shaker required the combination of a large 6 ft. x 6 ft. sliptable and a guided head expander of equal size. The design incorporated special plugs for quick release of the head expander, thus removing the need to undo hundreds of thermal barrier bolts. This is a great time saver, compared

to reconfiguring a standard system from vertical to horizontal – which may take up to several hours. The head expander's guidance frame allows fast rotation of the shaker without removing the head expander and allows a quickswitch to a smaller head expander. For testing heavy assemblies the design was optimised for manpower savings, minimising heavy component movement during the axis change process.

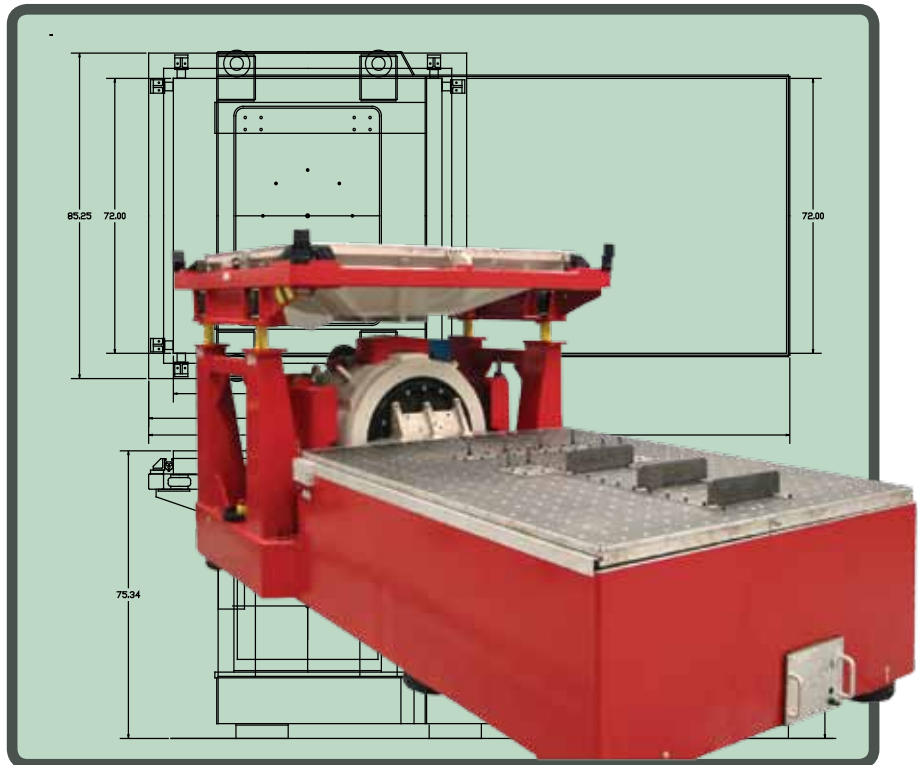

# PACKAGE TESTING

Most consumer products undergo vibration testing, with the most common form being package testing. Package testing is designed to simulate a product's journey from when it is boxed at the factory to when it's delivered to the customer's home.

One such system was designed to enable a customer to simultaneously test two plasma screen television sets, weighing 85 kg each in their transport boxes. The tests were designed to reproduce the effects of transport experienced by the televisions.

These tests allowed for the optimisation of the packaging design

and savings on materials such as polystyrene packaging. The customer used a combination of sine tests, typically <5 mm peak-to-peak in the 5 - 20 Hz range, and random tests (<1.5 g up to 200 Hz).

The system combines a rigidly mounted standard LDS V875-640 shaker with specially designed steel trunnions and a magnesium head expander, measuring 1.8 m x 2.2 m. It is supported by a load bearing platform. The basic over-turning capability of the load bearing platform is 5 kNm, and it is restrained by guide shafts which are part of the steelwork. Airbags located underneath

the trunnions isolate the vibration. Pneumatic isolation is also incorporated to prevent unwanted vibration being transmitted to the building.

Once on site, the head expander is positioned at floor level, allowing the loading and unloading of the payloads by pallet truck for quick turnaround of large test articles. A remotely operated safety mechanism to lock and unlock the load bearing platform had to be designed to allow access to the shaker.



V875-640 mounted in trunnions with load bearing platform and 1.8 m x 2.2 m head expander

## Data recording without ranges or limits



Brüel & Kjær's LAN-XI Notar™ allows PC-less recording directly to a small and rugged solid-state memory card for applications where the use of a PC is not an option such as in-flight or in-vehicle measurements or other harsh environments

# LOW FREQUENCY TESTING

## FIGHTING VIBRATION EMISSIONS

The need for higher machine performance has generally been accompanied by higher speeds and cutting rates as well as an increase in impact power in the field of forming. This results in increased vibrations being transmitted to the surroundings, which must be efficiently controlled. During the development process of suitable isolation mechanisms, a shaker system plays an important role.

The constant increase in productivity requires extreme efforts to keep vibration emissions within stringent targets for working conditions and comfort. Most critical are the emissions which are dissipated directly into the structure of the building. In order to minimise pulsating or sinusoidal vibrations, various isolating mechanisms are designed for machine mounting. The most challenging task is to keep the motion of the flexibly mounted machine within permissible limits of operation.

The efficiency of vibration isolation depends to a large extent on the relationship between the machine's speed/stroke rate and the natural vibration frequency of the isolator. In general, the lower the natural vibration frequency of the isolator, the greater its efficiency.

Bilz Vibration Technology AG designs and manufactures isolation mechanisms for machine mounting where it is very important to stimulate structures at very low frequencies of less than 1 Hz. To accomplish this, they must use the latest state-of-the-art test equipment. This was one of the



Photo courtesy of Bilz Vibration Technology AG

reasons why Bilz chose a LDS V650 shaker for their brand new 1600-Newton three-axis test bench. With all the critical components – electro-dynamic shaker, power amplifier and vibration controller – coming from a single source, the entire system could be fine-tuned to meet their extreme low frequency requirements.

The V650 shaker can be operated both vertically and horizontally, and the multi-

channel LASER<sub>USB</sub> vibration controller is operated in a velocity-controlled mode enabling Bilz to test isolation mechanisms across the frequency range of 0.5 Hz to 150 Hz or more. Thanks to very precise stimulation of the test platform, a variety of floor constructions can be tested, enabling Bilz to significantly speed up the design process.



The Quad LDS V9 (4 x 105 kN) Shaker System has been specially designed for a transport simulation application, testing structures at frequencies from DC and payloads exceeding 6 tonnes. With a cross-section of over 6 m x 3 m it is much larger than the vibration system interface plates. The capability to independently control the vibration acceleration at multiple positions on a single payload of this size is revolutionary.



# TRANSPORT SIMULATION

The payload interfaces for each of the four V9s are not connected to each other. Therefore to control their relative positioning, a new position indicator control stand has been developed.

A special version of the LDS Combo has been designed to incorporate a solid-trunnion vibrator body mounting, with the slidable combo frame being attached

directly to steel plates on top of a seismic mass. The base fabrication is designed to accept a load bearing platform used for vertical vibration.

An air-isolated seismic block has been designed so that all forces are transmitted to it. Testing is controlled using a Multiple Amplifier Control (MAC) system together with a Multi-input Multi-output (MIMO)

vibration controller to simultaneously control each V9 system independently, in order to achieve the required combined effect. Using Airglides, the four combos can be readily repositioned into multiple orientations to enable both vertical and horizontal testing of variously sized payloads.



Solid-trunnion Quad V9  
HBT 1220 and LBP 1430  
with independent control

BRÜEL & KJÆR FRANCE  
46 Rue du Champoreux, B.P. 33  
MENNECY, F-91540

Phone: +33 (0)1 69 90 71 00  
E-Mail: info.fr@bksv.com

BRÜEL & KJÆR GMBH (HQ)  
Linzer Straße 3  
D-28359 Bremen

Phone: +49 421 17 87 0  
E-Mail: info.de@bksv.com

BRÜEL & KJÆR GMBH Servicecenter Ismaning  
Carl-Zeiss-Ring 13  
85737 Ismaning

Phone: +49 89 92 3333 0

BRÜEL & KJÆR UK LTD  
Jarman Way, Royston  
Herts, SG8 5BQ

Phone: +44 (0) 1763 255 780  
E-Mail: ukinfo@bksv.com

SPECTRIS INSTRUMENTATION AND SYSTEMS SHANGHAI LTD  
Rm 1818 Beijing Shougang International Building, No. 60  
North Street, Xizhimen, Haidian District, Beijing, 1000880

Phone: +86 10 59935888  
E-Mail: info@bksv.com.cn

BRÜEL & KJÆR NORTH AMERICA INC  
2815-A Colonnades Court  
Norcross, GA 30071, USA

Phone : +1 (770) 209-6907  
E-Mail: bkinfo@bksv.com