

PRODUCT DATA

2260 Outdoor Gear — Type 3592

Security and weather protection for 2260 Investigator™ when used for long-term monitoring

Noise monitoring in out-of-the-way places need no longer be problematic. 2260 Outdoor Gear Type 3592 offers security and weather-protection for 2260 Investigator converting it into an all-weather noise monitoring system. Safe and dry in its robust, heat reflecting bright yellow case, the analyzer will operate unattended for more than 3 days. For longer periods the battery may be changed without interrupting measurements. You can also save yourself a site visit by using the modem dial-up facility to collect your results.

The system consists of a weatherproof case, Outdoor Microphone Kit, microphone extension cable, microphone tripod or user's mast, sealed lead-acid battery, charger for battery, DAT recorder (not supplied by Brüel & Kjær) and cables for interconnection. All components of the system may be ordered at once, or just those required for a specific application.

USES

- All-weather measurements using 2260 Investigator
- Semi-permanent noise monitoring
- Noise control
- Area planning
- Complaint investigation
- Plant noise measurement
- Tamper-proof workplace noise analysis
- Research

FEATURES

- Weatherproof case and microphone system
- Fulfils IEC Type 1 and ANSI Type 2 requirements
- Sound recording for documenting noise events
- 3 days monitoring using auxiliary 12 V battery
- Battery change without downtime
- Dynamic range 17 dB(A) to 150 dB_{pk}
- CIC check for reliable measurements
- Packs into one case for easy transport and setup
- Modular design – order what you need



2260 Outdoor Gear measuring traffic noise on a busy urban road

3592

2260 Investigator and Outdoor Noise Monitoring

2260 Outdoor Gear Type 3592 converts 2260 Investigator into an all-weather noise monitoring system. The outdoor gear system is modular, allowing you to assemble a monitoring system that meets your requirements exactly.

The central component of the outdoor gear system is the tough ABS case. With the lid closed, the case is rainproof to IP 43 standards and is well insulated against shock and heat. The case is yellow to reflect sunlight, keeping the interior cooler. A rainproof cable hatch is provided for up to 4 cables. The case also allows transmission of cellular phone signals if the cable-free modem facility is used.

Security

The case has provision for a padlock to protect the equipment against tampering, for example when measuring in a public place or when conducting long-term workplace-noise analysis. And by attaching the padlock to a chain/wire, the case can be anchored to a fixed object to prevent theft.

Modular Design

Inside the case is a pre-cut foam inlay into which the various accessories of the system snugly fit (see Fig. 1). As well as the necessary 2260 Investigator, your core accessories are likely to be the Outdoor Microphone Kit, Battery QB 0051 and DAT recorder.

Outdoor Microphone Kit UA 1404

Outdoor Microphone Kit UA 1404 shields the microphone and preamplifier against weather and wind noise, and ensures the proper frequency response and directional response according to IEC and ANSI standards. 2260 Investigator's own microphone and preamplifier are easily disconnected and plugged into the UA 1404 kit, connecting to the 2260 Investigator via a 3 m or 10 m microphone extension cable.

The microphone system is mounted on a UA 0801 lightweight tripod for which space is provided in the case inlay, or the heavier UA 0587 tripod. Alternatively, the microphone system may be mounted on a tube with 1" standard thread provided by the user. The cable runs inside or outside the tube as required.

Power Considerations

Battery QB 0051, Charger ZG 0404

Battery QB 0051 is a 12V sealed lead-acid battery that extends the operating time of the 2260 Investigator by at least ten times, allowing more than three days unattended operation. The battery can be fully recharged in 15–20 hours by connecting it to mains powered Charger ZG 0404¹. You can also operate the outdoor gear from an external 12 V source, for example a vehicle battery. Depending upon the Ah rating of the battery, you can extend the operating time to weeks of unattended operation. If a mains power supply is available at the site, Outdoor Gear Type 3592 can be run continuously without using lead-acid batteries. And when swapping auxiliary batteries, or in the unlikely event

¹ The ambient battery temperature must be 15 to 25°C (59 to 77°F) when recharging

of a mains power failure, the measurement system will seamlessly switch over to 2260 Investigator's internal dry cells (if fitted), ensuring you never miss any measurements.

Operating time

When the 2260 is battery powered, 30% longer operating time is achieved by not using the display light, spectrum display or outputs. If a DAT recorder is also powered from the 12V battery, the battery life is reduced by approximately 30% (see Specifications).

Total Independence

Fully remote monitoring

Under normal circumstances you would be present when a sound-level measurement was being done. You would do a calibration before measurement, and during measurement note, using your experience, the nature of the sound being measured. In an unattended monitoring situation a calibration check and judgement of noise characteristics are also desirable, but normally difficult. However, with Outdoor Gear Type 3592 both of these things (and more) are possible.

Fig. 1 Interconnection of accessories for a typical Type 3592 setup

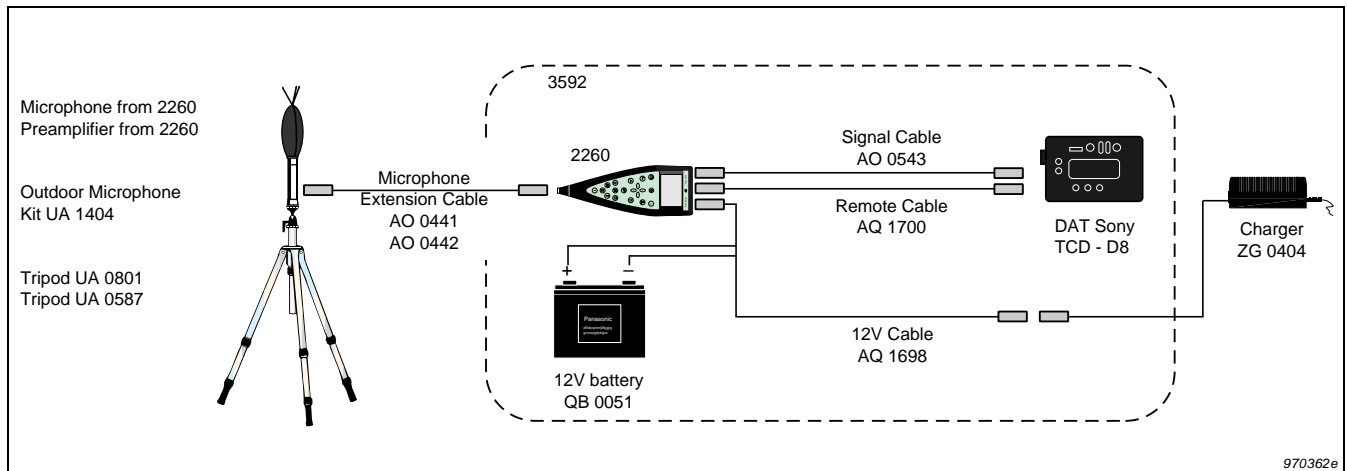

Calibration check

After doing a standard acoustic calibration, program the CIC routine that is part of Enhanced Sound Analysis 20 kHz Software BZ 7206. At intervals you select, microphone electrical parameters are checked (using an internal electrical signal), and stored. After the measurement is complete, the stored values are used to confirm measurement reliability. The CIC facility also is useful for microphone diagnostics, since specific electroacoustic and mechanical faults cause corresponding specific deviations from the norm.

Event monitoring

Enhanced Sound Analysis Software 20 kHz BZ 7206 can be set in two measurement modes – logging and event logging. Event logging mode allows 2260 Investigator to measure background sound levels using one set of parameters and, when triggered by an event, use another set for the duration of the event.

For example, you might set an event trigger to occur when the $L_{AF(Inst)}$ exceeds 70 dBA. As long as the level is below this value, 1 minute logging is in operation (see Fig. 3). As soon as the level goes above this (for example a compressor starts), the sampling rate is reduced to 1 second intervals (event logging) and continues until the level drops

below the threshold value. In this way you have a higher resolution account of the noise levels during the event.

Fig. 2
Inlay in Type 3592 case

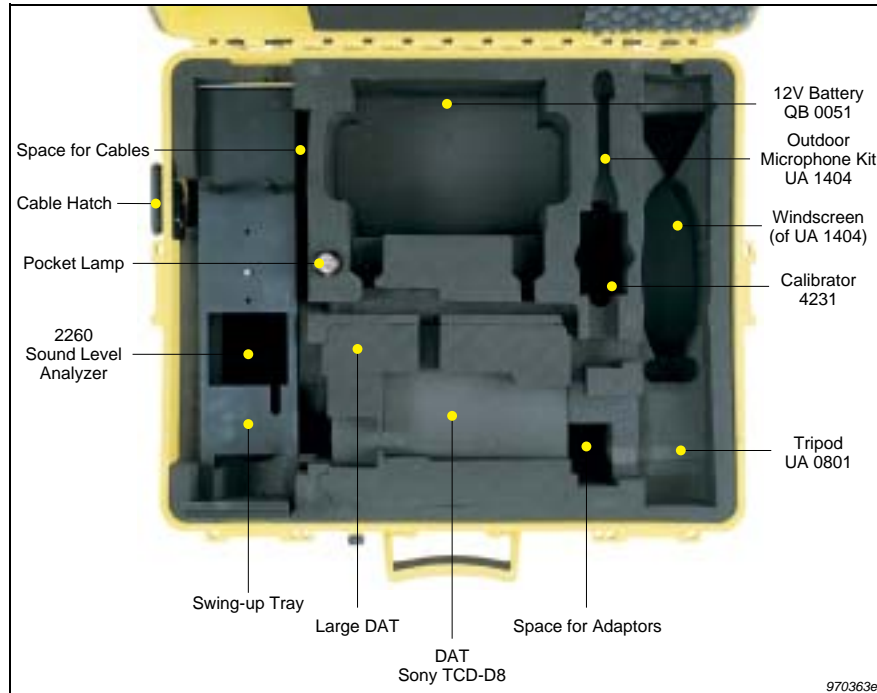
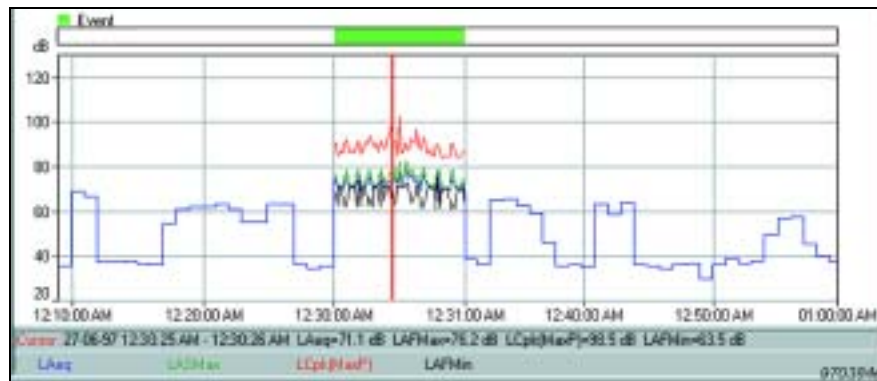

Fig. 3
Example results from an event logging file. You can see the timebase change from 1 minute to 1 second intervals during the event and the event marker (green bar) that can be used by Evaluator Type 7820/21 software to post-process logged data



Events may be detected automatically using criteria you select, or initiated by remote command through the RS232 interface. Event measurement may also be initiated using an external trigger pulse or by activating a softkey.

DAT recording

In the above example of event monitoring, you cannot be sure what caused the event unless you could hear it. Was it the compressor, aeroplane or just a barking dog? To judge this, use the DAT recording facility offered by 2260 Investigator, where the microphone's signal is fed directly onto the tape for subsequent listening. The 2260's remote control signal is a pulse or a code that can control the Sony TCD-D8 DAT recorder. From stand-by mode, DAT recording starts within 1-2 s.

Sound recording

To help with the documentation of the occurrence of a sound, and to be certain of what caused a marked event, you can record sound directly onto your PC's hard disk. With Noise Explorer Type 7815 or Evaluator Type 7820 installed on your PC, you can use 2260 Investigator to control sound recording on the PC during measurements. The only limit to duration is the size of the hard disk. Sound recording can be tagged to one or more markers. There is a 60 s sound buffer in the PC to permit editing of markers

up to one minute after the event has occurred. Recordings are time stamped and stored as .wav files. After data transfer to Noise Explorer or Evaluator, the data is automatically merged with the sound recordings. These are then marked in the profile display and can be replayed. You use the cursor position in the profile display to decide which part of the recording you want to hear.

Remote download

The new modem dial-up facility offered by the 2260 platform allows you to remotely log-on to the 2260 Investigator and download measurement files, freeing disk space for more results and saving you a site visit. The modem interface is standard RS-232, so you can connect either a land-line modem or a mobile phone with a digital interface. The case has a space for the modem/mobile phone, and it is transparent to radio waves.

Analysis and Documentation

Transferring Data

After measurement, the stored data may be inspected in the 2260 Investigator using its powerful display facilities. For long-term storage, overview and post-processing, the data may be transferred to a PC using Noise Explorer software Type 7815, Evaluator Type 7820 software, or using 2260 Investigator's spreadsheet output format. Both Noise Explorer and Evaluator can be used for remote downloads via the RS-232 interface.

Specifications – 2260 Outdoor Gear Type 3592

2260 Investigator with UA 1404 and BZ 7206¹

STANDARDS

IEC Type 1 and ANSI S1.4 Type 2

WIND NOISE ATTENUATION

> 15 dB for wind speeds up to 120 km/h

MEASURING RANGES

Linear Operating Range: 80 dB adjustable to give full-scale readings from 70 dB to 130 dB in 10 dB steps (Attenuator ZF 0023 effectively increases all full-scale readings by 20 dB)

BACKGROUND MEASUREMENT

Measurement Time: 1 s to 100 days

Logging Rate: 1 s to 100 hours interval

Auto CIC Check: Up to 4 times a day

EVENT MEASUREMENT

Trigger types:

- External: switch via RS232 connector
- Remote: via RS232 commands
- Softkey: by pressing softkey
- Level: via setup of levels and durations

Event ID: through number and time

OPTIONS FOR STORING DATA

Separately for Background and Event:

- All

- Without Statistics
- Major Parameters
- Nothing

BZ 7203 FEATURES

BZ 7203 may be used instead of BZ 7206; it offers extended broadband measurement range (110 dB) and noise profile facilities, but no event or spectrum analysis features

OUTPUT SIGNALS

Aux.1 Output options:

- Off
- LAF(Inst.) (DC output)
- Reference (DC calibration level)
- Meas. Status (during measurement)²
- Input C/L-weighted (AC output)
- Event C/L-weighted (AC during event)
- Event Status (during events)²
- Limited Event Status (1 s to 1 hour)²

AUX.2 OUTPUT OPTIONS

- Off
- LAF(Inst.) (DC output)
- Reference (DC calibration level)
- Meas. Status (during measurement)²
- Input A-weighted (AC output)
- Event A-weighted (AC during event)
- Event Status (during events)²
- Limited Event Status (1 s to 1 hour)²

¹For detailed specifications, see separate Product Data sheets.

²Format options: High Level, DAT

Power Supply

TYPICAL CURRENT DRAIN AT 12.7 V

2260 Investigator: 250 mA to 350 mA, depending on setup
DAT Recorder – Stop Condition: 115 mA
DAT Recorder – Recording: 140 mA

12V BATTERY QB 0051

Type: Sealed lead-acid
Nominal Voltage: 12 V
Nominal Capacity: 33 Ah
Battery Life: Worst case setup > 72 hours at 20°C (68°F)

12V BATTERY CHARGER ZG 0404

Nominal Voltage: 12 V
Charging Current: 2.5 A (maximum)
Charging Time: 15–20 hours
Temperature (charging): 15–25°C (59–77°F)

DAT Recorder

Type: Sony TCD–D8
Batteries: 4 size AA (LR6)
Battery Life: 3 hours with Sony LR6/AM3
Recording Time: 120 minutes (standard recording speed)
Frequency Response: 20 Hz–22 kHz
S/N Ratio: > 87 dB
Total Harmonic Distortion: < 0.008%
Wow and Flutter: < ±0.001%
Weight (including batteries): 510 g (1.1 lb.)
Dimensions: 133×37×88 mm (5.2×1.5×3.5 in.)

Ordering Information

Type 3592: 2260 Outdoor Gear
Consists of:
Case with inlay, pocket lamp and cable straps

Optional Accessories

BASIC SYSTEM

2260 Sound Level Analyzer
BZ 7206 Enhanced Sound Analysis 20 kHz Software
UA 1404 Outdoor Microphone Kit
UA 0801 Tripod (space in case inlay)
UA 0587 Tripod
UA 0801 Lightweight Tripod
AO 0441 3 m Microphone Ext. Cable
AO 0442 10 m Microphone Ext. Cable
QB 0051 12 V Battery
AQ 1698 Cable for 12 V Supply
AQ 1700 Cable for DAT Remote
AO 0543 Cable 2260 to Jack
ZG 0404 Battery Charger, 100–240 VAC¹
ZH 0631 Handswitch

1. Power cable depends on country

Mechanical Specifications

CASE KE 0373

Dimensions: 577×503×229 mm (22.7×19.8×9.0 in.)
Material: ABS plastic alloy
Weight: 10 kg (22 lb.) (with all options installed 24 kg (53 lb.))

12V BATTERY QB 0051

Weight: 12 kg (26.5 lb.)
Dimensions: 197×132×160 mm (7.7×5.2×6.3 in.)
Connections: M6 threaded-posts

12V BATTERY CHARGER ZG 0404

Weight: 0.42 kg (0.9 lb.)
Dimensions: 136×80×56 mm (5.4×3.1×2.2 in.)
Connections: Socket for mains cable, output cable with cigarette lighter plug

Environmental Specifications

OPERATING TEMPERATURE RANGE

UA 1404: –30 to +150°C (–22 to +302°F)
Case: –29 to +71°C (–20 to +160°F)
12 V Battery QB 0051: –15 to +50°C (5 to 122°F)
Type 2260: –10 to +50°C (14 to 122°F)
Charger ZG 0404: 0 to +40°C (32 to 104°C)
DAT Recorder: Not specified

RAIN

Outdoor Microphone Kit UA 1404: Rainproof to IP44
Case KE 0373: Rainproof to IP43

DURABILITY

Urban Environment: Cleaning and drying required after 4 weeks
Microphone System Overhaul: > 4 months

DAT RECORDER

TCD–D8 DAT Recorder from Sony
DCC–E260HG Sony Car Battery Cord

2260 SOFTWARE

BZ 7206 Enhanced Sound Analysis 20 kHz Software
BZ 7203 Noise Profile

MAINS POWER SUPPLIES FOR 2260

ZG 0386 EU Version
ZG 0387 UK Version
ZG 0388 US Version

CALIBRATION

4231 Sound Level Calibrator
4228 Pistonphone

INTERFACING

AO 1386 Cable for use with PC
UL 1008 32 Mbyte Memory Card

ANALYSIS AND DOCUMENTATION

Type 2322 Portable Printer
Type 7815 Noise Explorer software
Type 7820 Evaluator software

Brüel & Kjær reserves the right to change specifications and accessories without notice.