

# PRODUCT DATA

## Generator, 4/2-ch. Input/Output Module — Type 3109



### **Flexibility**

Type 3109 is an all-in-one input/output module. Four independent input channels are each equipped with two input connectors (BNC/BNT and LEMO) which allows you to mix and match your input types. The two output channels can be used as signal generators at frequencies up to 25.6 kHz.

Type 3109 is also capable of two methods of cable break detection and is prepared for use with transducers with remote identification – serial number, sensitivity, etc.

**3109**

---

## Uses and Features

---

### USES

- 4 input channels for multichannel acoustic and vibration measurements
- 2 output channels for system excitation for acoustic and vibration measurements
- Multichannel applications such as modal analysis, normal-mode testing, general sound and vibration, STSF and Non-stationary STSF

### FEATURES, INPUT

- Each of 4 input channels with independent CCLD and preamplifier input connectors (BNC and LEMO), allowing any combination of transducers
- Supports transducers with remote ID via µLAN interface
- Cable fault detection
- Overload detection for out-of-band frequencies
- DC, 0.7 Hz and 22.4 Hz high-pass filters, independently set for each channel
- Independent input ranges for each channel, with autorange
- Long, real-time, time records: up to 4096 k samples, total for the enabled number of channels (shared memory between input and output)
- Powerful built-in digital signal processors
- Automatic DC-offset compensation

### FEATURES, OUTPUT

- Output up to 25.6 kHz
- Long output buffer: up to 4096 k samples (shared memory between input and output)
- Downloadable functionality via application software, including sine, dual sine, multisine, random, pseudo-random, periodic random, pulse signals, built-in trigger for data collection, pink filtering and user-defined waveforms

---

## Input

---

*Type 3109 offers outstanding input and output capabilities on the same module, whether you're exciting a system or making multichannel measurements with a variety of transducers simultaneously.*

Generator, 4/2-ch. Input/Output Module Type 3109 is intended for use with the Intelligent Data Acquisition (IDA) System Type 3561. Each channel offers a direct (BNC/BNT<sup>1</sup>) input connector for CCLD (including DeltaTron<sup>®</sup>) transducers and a preamplifier (7-pin LEMO) input connector for, for example, Brüel & Kjær Falcon Range<sup>®</sup> Microphone Preamplifiers.

LEDs indicate the status of the module (overload, recording). Downloaded DSP software defines the functions available with the module, for example, decimation and zoom for recording time histories.

---

<sup>1</sup> Ch1. comes equipped with a BNT connector, to provide a DC supply for a Tacho Probe

## Cable Fault Detection

Type 3109 uses two methods to detect cable breaks. For microphones, the supply current to the microphones is monitored on-line and in real time. If the current exceeds the upper or lower limit of the allowed band, an error event is generated.

For DeltaTron accelerometers or microphones using DeltaTron preamplifiers, the supply voltage can be monitored off-line. If the acceptable limits are exceeded, an error event is generated and you can stop the measurement and measure the working voltage to help determine the cause of the error.

## Independent Channels

The input channels on the module can be set up independently. This means that you can set up the high-pass filters and input gain separately and attach different types of transducers to different channels.

## Remote ID

Type 3109 is prepared for use with transducers with remote ID – serial number, sensitivity, etc.

---

## Output

---

*The two output channels on Type 3109 can be used as signal generators with a frequency range from 0 to 25.6 kHz and can supply all the signals necessary for performing a system analysis*

Type 3109 is designed around a powerful digital signal processor and a 24-bit D/A convertor, and has exceptional flexibility, stability and accuracy. Output levels are adjustable in hardware from 5 mV to 5 V. Lower levels are possible by scaling the signal to the D/A converter. The signal can be referred to ground or floating. It is possible to add a DC offset, but any unwanted DC offset is automatically removed.

## Waveforms

Waveform functionality is downloadable via application software.

*Fig. 1 System schematic for Type 3109*

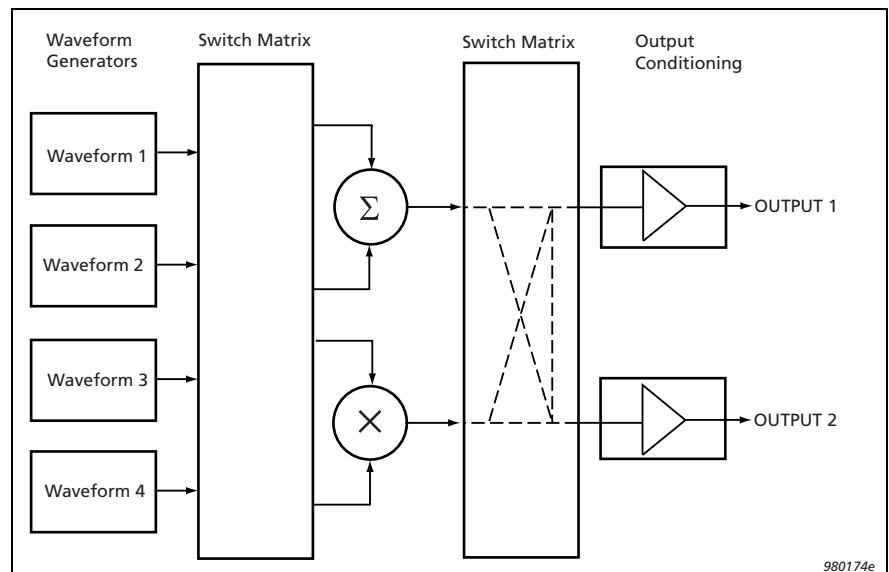

Below, some examples of waveform generators are listed to show the performance of the module. The waveforms are:

<i>Sine and Dual Sine</i>	Single and dual superimposed sine waves have high spectral purity. Both sine and dual sine waveforms can be swept. Dual sine waves can be combined in fixed/swept, swept/swept or fixed/fixed modes.
<i>Multisine</i>	The multisine waveform has a low crest factor to extract maximum RMS levels from a shaker. The line spectrum of the signal can be matched to the frequency lines of subsequent analysis.
<i>Random</i>	The signal is produced by a pseudo-random generator with a very long sequence length. The random signal can be band-limited to match the selected frequency span, and band-translated for zooming.
<i>Pseudo-random</i>	The signal has a line spectrum that can be matched to the frequency lines of subsequent analysis. The waveform has Gaussian amplitude distribution, and signals can be band-limited and band-translated for zoom.
<i>Periodic Random</i>	The signal is produced by repeating a pseudo-random block a selectable number of times. The phase spectrum is then shuffled, and the new pseudo-random block is repeated, and so on. A trigger pulse is used to start the measurement at the start of the last block of each pattern.
<i>Pulse</i>	Three pulse shapes are available, including a rectangular impulse which can be as short as 16 $\mu$ s, with user-defined width and repetition interval.
<i>User-defined</i>	For ultimate control of testing, and to make system analyses with “real” excitation signals, user-defined waveforms can be programmed into the generator. Time functions, complex frequency spectra or autospectra can be downloaded into the module and stored in a buffer memory. For an autospectrum, phase information is added to reconstruct the time waveform, and the phase can be specified to give a pseudo-random, or periodic random signal. In the latter case the function is identical to the periodic random waveform, but the shape of the frequency spectrum is user-defined.
<i>Pink Noise</i>	A digital filter can be applied to any wideband signal to give it a “pink noise” roll-off of 3 dB/octave above 22.4 Hz.
<i>Waveform Repetition</i>	Waveforms can be repeated with a selectable period, for a specified number of times or continuously. Fixed sine and random signals can be gated to give a burst with selectable width.
	<b>Control</b>
<i>Trigger</i>	Type 3109 provides a trigger which you can use to trigger data collection. The timing of the trigger depends on the waveform being generated, generally it is at the start of a pattern or burst.
<i>Soft start &amp; stop</i>	This function ramps the signal level up when the generator starts and down when the generator stops. The ramp is logarithmic, and you can select both the start/stop amplitude level and the ramp time.
<i>Delay to measurement</i>	To allow a test system to reach a steady-state condition, you can delay the start of recording for a selected time after the generator start.

# Specifications 3109

## Input

### UPPER FREQUENCY

12.8 kHz at  $f_s = 32.768$  kHz

25.6 kHz at  $f_s = 65.536$  kHz

### SAMPLING

32768 Hz & 65536 Hz

A/D Conversion: 16-bit

Input Connector: 1×BNT (ch.1); 3×BNC (ch.2-4); 4×7-pole LEMO (BNC & LEMO connectors sited in parallel)

Supply for Tacho Probe (ch.1): 6 V, max. 60 mA

Polarization Voltage: 0 or 200 V (with Power Supply Type 2826 only)

### Input Coupling:

22.4 Hz high-pass filter @ -0.1 dB, slope -18 dB/oct ( $f_L = 22.4$  Hz)

0.7 Hz high-pass filter @ -0.1 dB, slope -6 dB/oct ( $f_L = 0.7$  Hz)

DC Direct ( $f_L = 0$  Hz)

### Analog Special Functions:

CCLD on/off

Charge Injection Calibration:

Max.  $V_{out}$ :  $5V_{rms}$

Frequency Range: 0 to 25.6 kHz

Resolution: 24-bit

Analog Self-test: Functional Check

Analog and Digital Offset Adjustment: 60 dB below Max. Input

### Cable Fault Detection:

#### Transducer Current Fault Detection:

+15 V transducer supply current monitoring:

Dual Current Detector

Range: 0 to 10 mA, 8-bit resolution

#### Remote ID between Transducer and Front-end:

Communication via  $\mu$ LAN

- CCLD transducers

- Falcon preamplifiers

Working Voltage Meas. for CCLD:  $35V_{peak} \pm 0.5V$

### INPUT VOLTAGE

7 ranges from  $7.071 mV_{peak}$  to  $7.071 V_{peak}$  in 10 dB steps

### INPUT IMPEDANCE

Direct, Microphone:  $1 M\Omega \parallel <200 pF$

CCLD:  $>100 k\Omega \parallel <200 pF$

### MAXIMUM INPUT VOLTAGE

$50V, 35V_{rms}$

### MAXIMUM INDUCED COMMON MODE VOLTAGE

$1V_{peak}$  DC — 4 MHz

$10V_{rms}$  4 MHz — 80 MHz

### SUPPLY FOR CCLD ACCELEROMETERS

4 mA from +28 V

### COMMON-MODE REJECTION

DC: 50 dB

0 to 1 kHz: 40 dB

1 kHz to 12.8 kHz: 30 dB

### CROSSTALK (SOURCE: 50 $\Omega$ )

Between any two channels of a module or between any two channels in different modules:

0 to 2 kHz: -100 dB

2 kHz to 12.8 kHz: -85 dB

12.8 kHz to 25.6 kHz: -80 dB

### ATTENUATOR LINEARITY

$\pm 0.1$  dB

### ANTI\_ALIASING FILTER ( $f_s = 32768$ Hz & $f_s = 65536$ Hz)

Provides at least 80 dB attenuation of those input frequencies which can cause aliasing

Passband: DC to 25.6 kHz @ -0.1 dB, slope -18 dB/oct

### OVERLOAD DETECTION

Applied before filters

### TOTAL HARMONIC DISTORTION

At least -80 dB below max. input ( $\approx 0.01\%$ )

### NOISE (LINEAR 10 TO 25.6 kHz)

Input Range	Equivalent Input Noise
7.071 mV	$3 \mu V_{rms}$
22.36 mV	$3 \mu V_{rms}$
70.71 mV	$5 \mu V_{rms}$
223.6 mV	$10 \mu V_{rms}$
707.1 mV	$31 \mu V_{rms}$
2.236 V	$100 \mu V_{rms}$
7.071 V	$316 \mu V_{rms}$

### OVERALL FREQUENCY RESPONSE

$f_L$  to  $f_U$ :  $\pm 0.1$  dB

### AMPLITUDE LINEARITY

0 to 40 dB below full scale:  $\pm 0.1$  dB

40 to 60 dB below full scale:  $\pm 0.4$  dB

60 to 80 dB below full scale:  $\pm 1.0$  dB

### ABSOLUTE AMPLITUDE PRECISION

$\pm 0.1$  dB, 2.236 V input range (1.024 kHz)

### CHANNEL-TO-CHANNEL MATCH (any input range)

Maximum Gain Difference: 0.2 dB from lower frequency limit,  $f_L$  to upper frequency limit,  $f_U$

Maximum Phase Difference (within one frame):

$1.3^\circ - 0.1^\circ \times (f/f_L)$  from  $f_L$  to  $12 \times f_L$

$0.1^\circ$  from  $12 \times f_L$  to 640 Hz

$0.1^\circ \times (f/640)$  from 640 Hz to 6.4 kHz

### CHANNEL-TO-CHANNEL MATCH (same input range)

Maximum Gain Difference:

0.2 dB from lower frequency limit,  $f_L$ , to upper frequency limit,  $f_U$

Maximum Phase Difference (within one frame):

$1.3^\circ - 0.1^\circ \times (f/f_L)$  from  $f_L$  to  $12 \times f_L$

$0.1^\circ$  from  $12 \times f_L$  to 1280 Hz

$0.1^\circ \times (f/1280)$  from 1280 Hz to 25.6 kHz

## Output

### UPPER FREQUENCY

25.6 kHz at  $f_s = 65.536$  kHz

### SAMPLING

D/A Conversion: 24-bit

Output Connector: 2 × BNC

Output Coupling: DC Direct ( $f_L = 0$  Hz), Offset residue: 60 dB below max. output

### Analog Special Functions:

Analog Self-test: Functional Check

DC Offset Adjustment: Digital

### OUTPUT VOLTAGE RANGE

(3 ranges):  $70.7 mV_{peak}$ ,  $707 mV_{peak}$ ,  $7.071 V_{peak}$

### OUTPUT IMPEDANCE

$50 \Omega$

### MAXIMUM INDUCED COMMON MODE VOLTAGE

$1V_{peak}$  DC - 4 MHz

$10V_{rms}$  4 MHz - 80 MHz

### COMMON MODE REJECTION

1 Hz to 1 kHz: 50 dB

1 kHz to 25.6 kHz: 40 dB

# Specifications 3109 (cont.)

## CROSSTALK

Between any two channels of module or between any two channels in different modules

0 to 2 kHz: -100 dB

2 kHz to 25.6 kHz: -85 dB

## ATTENUATOR LINEARITY

±0.1 dB

## VARIABLE ATTENUATOR

0 to -20 dB, 10-bit resolution

## ANTI\_ALIASING FILTER ( $f_s = 32768$ Hz & $f_s = 65536$ Hz)

Provides at least 80 dB attenuation of those input frequencies which can cause aliasing

Passband: DC to 25.6 kHz @ -0.1 dB, slope -18 dB/oct

## HARMONIC AND SPURIOUS DISTORTION PRODUCTS (in band)

< 80 dB or 1  $\mu$ V, whichever is greater

## OUTPUT NOISE

Output Range      Equivalent Output Noise

70.7 mV              3  $\mu$ V<sub>rms</sub>

707 mV              20  $\mu$ V<sub>rms</sub>

7.07 V                200  $\mu$ V<sub>rms</sub>

## OVERALL FREQUENCY RESPONSE

±0.1 dB re 992 Hz, over the interval 1 mHz to 25.6 kHz

## FREQUENCY ACCURACY AND STABILITY<sup>1</sup>

0.0025% without warm-up (no adjustment necessary)

## AMPLITUDE LINEARITY

0 to 40 dB below full scale: ±0.1 dB

40 to 60 dB below full scale: ±0.4 dB

60 to 80 dB below full scale: ±1.0 dB

## ABSOLUTE AMPLITUDE PRECISION

±0.05 dB at 992 Hz, 1 V<sub>rms</sub>, 20°C

±0.1 dB at 992 Hz, 1 mV to 3.5 V<sub>rms</sub>

## CHANNEL-TO-CHANNEL MATCH (any output range)

Maximum Gain Difference: 0.2 dB from lower frequency limit, 0 Hz to upper frequency limit  $f_U$

Maximum Phase Difference (within one frame):

to be determined

## CHANNEL-TO-CHANNEL MATCH (same output range)

Maximum Gain Difference: 0.2 dB from lower frequency limit,  $f_L$ , to upper frequency limit,  $f_U$

Maximum Phase Difference (within one frame):

1. Obtained together with Synchronization Module Type 7530

to be determined

## Digital Signal Processing, Input and Output

The functionality of Type 3109 is dependent on the DSP software downloaded from the IDA bus (part of application software)

## PROCESSOR

Motorola DSP56002 and DSP56301 @ 80 MHz

## RECORD SIZE

4096 k total samples for enabled channels (shared for Input and Output)

## Power Supply

Power Supply Module Type 2823 or 2826

## POWER CONSUMPTION

14.8 W (max. value)

Voltage (V)	Typical (mA)	Max. (mA)
-15	225	250
+5	800	-
+8	150	160
+15	250	300
+28	30	-
+200	0	2

## Dimensions (excluding connectors)

Type 3561 module dimensions

Height: 134.0 mm (5.28 in)

Length: 42.5 mm (1.67 in)

Width: 234 mm (9.21 in)

Weight: 0.71 kg (1.56 lb.)

## Compliance with Standards



When incorporated into Intelligent Data Acquisition System Type 3561, Type 3109 complies with the system standards stated in the Product Data for Type 3561 (BP 1447)

# Ordering Information

**Type 3109:** Generator, 4/2-ch. Input/Output Module

**Includes the following accessories**

**JP0169**              Shorting Plug

## Optional Accessories

**JP0145**              BNC to 10-32 UNF Plug Adapter

**AO 0526**

4p Microtech to 3×BNC Cable  
3×BNC to multiplug for triaxial transducers

**Type 2646**

DeltaTron Amplifier

**Type 4506**

OrthoShear Accelerometer

**Type 4935**

Array 1/4" Microphone

**Type 4188**

Falcon 1/2" Microphone

**Type 4189**

Falcon 1/2" Microphone

**Type 2669L**

Falcon Range 1/2" Microphone Preampifier

Brüel & Kjær reserves the right to change specifications and accessories without notice