

TIRAvib

Vibration generator

TIRAvib 5880
TIRAvib 5880/LS



➤ **Model TV 5880:**

Sine: 8000 N (815 kgf); Random: 4000 N (408 kgf); Shock: 8000 N (815 kgf); Displacement: 25.4mm

➤ **Model TV 5880/LS:**

Sine: 8000 N (815 kgf); Random: 8000 N (815 kgf); Shock: 16000 N (1630 kgf); Displacement: 50.8mm

➤ **automatic load compensation**

➤ **air cooled**

DESCRIPTION

The vibration generators TV 5880 and TV 5880/LS reproduce environmental conditions over a very wide frequency band.

The vibration generator operates in sine, random and shock mode under controlled conditions. Several features make the vibration generators an ideal testing instrument for use in the field of quality assurance and R&D in laboratories.

TIRA vibration generators are designed for continuous operation. They are fitted with a light weight rugged magnesium armature and a tested and proven suspension system which provides excellent lateral and rotational restraint as well as axial stiffness.

A unique pneumatic load support system guarantees a full nominal displacement with a maximum permitted vertical load of 150 kg. Several optional features, such as external load supports and horizontal oil film slip tables, make the TV 5880 vibration generator universal even to test objects of large dimensions in three axis.

The digital power amplifiers are provided with protection interlocks which guarantee the rated performance of the complete system.

The LS version of the generator enables Shock-testing of up to 51 mm displacement to be carried out.

Digital Vibration Control systems offer the user sophisticated, powerful DSP hardware with a full range of sine, random, shock and mixed mode software complete with a graphical display unit.

TIRA's fully equipped package enables customers to test under all national and international standards such as DIN, ASTM, BS, MIL, IEC, etc...

POWER AMPLIFIER

FOR TIRAvib 5880

sine continuous rating 12000 VA
voltage 110 V
current 110 A
distortion < 1 %
weight 200 kg
size (WxHxD) 600x2100x850mm

FOR TIRAvib 5880/LS

sine continuous rating 18000 VA
voltage 110 V
current 165 A
distortion < 1 %
weight 300 kg
size (WxHxD) 600x2100x850mm

PNEUMATIC RECENTERING

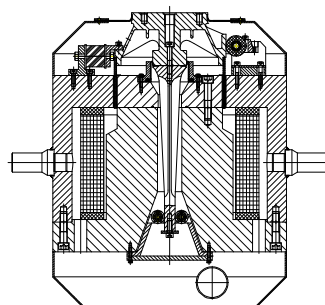

STANDARD SUPPLY

- Automatic Load compensation - pneumatic compressed air requirement 0.6 Mpa
- Air isolation-natural frequency < 6 Hz
- Air filter
- Trunnion with high mobility (180°)
- Cooling blower

Technical Specification

		TIRAvib 5880	TIRAvib 5880/LS
Rated peak force [N]	Sine/Random/Shock	8000 / 4000 / 8000	8000 / 8000 / 16000
Frequency range		DC-3000	DC-3000
Max. rated travel [mm]		25.4	50.8
Max. velocity [m/s]	Sine/Random/Shock	1.3 / 1.3 / 1.7	1.7 / 1.7 / 2.5
Max. acceleration [g]	Sine/Random/Shock	108 / 54 / 108	92 / 92 / 184
Rated current [A]		90	140
Nominal impedance [W]		0.9	0.5
Suspension stiffness [N/mm]		65	50
Effective moving mass [kg]		7.5	8.8
Max. test load [kg]		150	150
Main resonance frequency [Hz]		> 3000	> 3000
Weight with trunnion [kg]		1000	1000
Stray magnetic field [mT] (150 mm above table)	without/with degauss kit	< 8.5 / < 0.5	< 8.5 / < 0.5
Cooling [m ³ /h]		510	510
Interlocks		Temperature Overtravel Airflow	Temperature Overtravel Airflow

PERFORMANCE DIAGRAM TV 5880

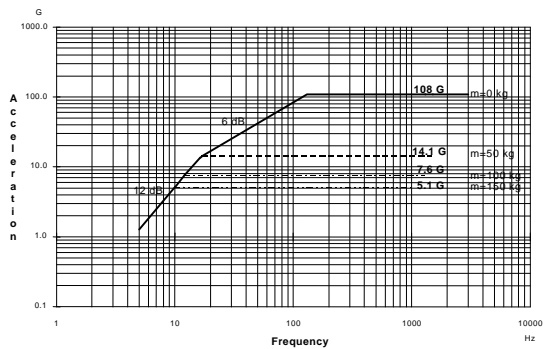

PERFORMANCE DIAGRAM TV 5880/LS

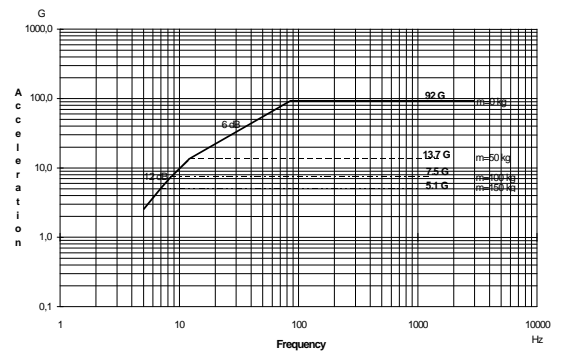

DIMENSIONS

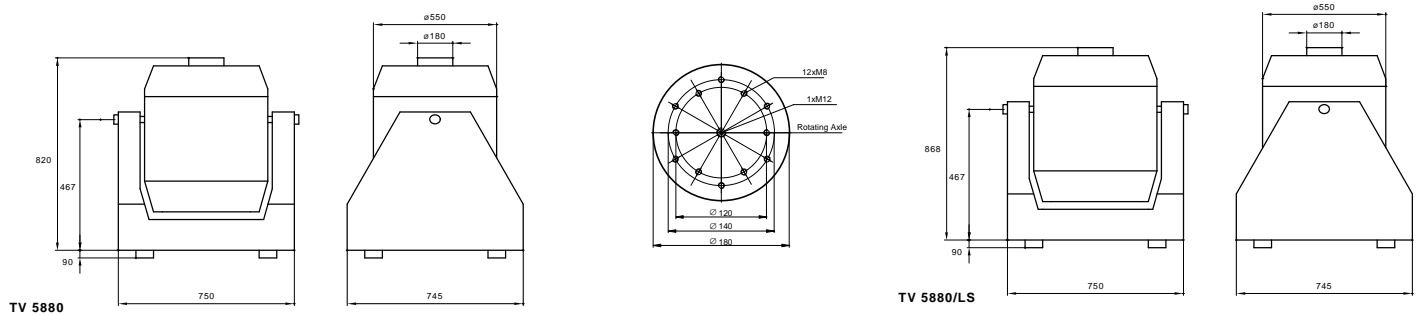

MANUFACTURER



Eisfelder Straße 23-25
D-96528 Schalkau
Telefon +49 36766 / 280-0
Telefax +49 36766 / 280-99
e-mail: ST@tira-gmbh.de
www.tira-gmbh.de

- ◆ MEASURING
- ◆ TESTING
- ◆ BALANCING
- ◆ CNC



PRODUCT RANGE

- Shaker 9 N - 245 kN
- Servohydraulic up to 1000 kN
- Longstroke systems up to 600 mm
- Amplifier, digital / analog
- Modal shaker
- Vibrations control system
- Sine, Random, Shock, Mixed mode
- Oil film slip table for horizontal test
- Climate and temperature system
- Headexpander and special construction