

Product Data

Impedance Heads — Types 8000 and 8001

FEATURES:

- Piezoelectric accelerometer and force gauge sharing the same housing and mounting point
- Individual calibration charts
- High sensitivity accelerometer
- Operating frequency range up to 10kHz
- Operating temperature range up to 260°C (500°F)

USES:

- Point measurements of mechanical mobility and impedance of light structures
- Point measurement of damping, loss factors and natural frequencies at points on light structures and materials
- Calibration of the Brüel & Kjær Artificial Mastoid Type 4930 (Type 8000 only)
- Biological measurements (Type 8000 only)

Impedance Heads Types 8000 and 8001 contain an accelerometer mounted on top of a force gauge, which allows the simultaneous measurement of a force and an acceleration at the same point. The impedance heads are designed to provide accurate and repeatable measurements at a point on a light structure.

Impedance heads offer a simple approach to the measurement of point mechanical mobilities and impedances. They can be used on a wide range of structures, including rotor blades, polymers, rubbers, the human body, artificial mastoids, fruit, welds, wood and metal panels.

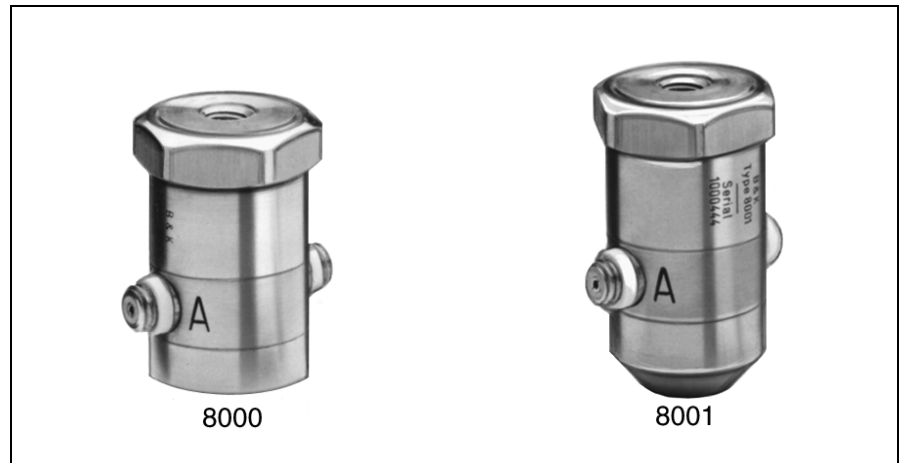

Impedance Heads Types 8000 and 8001 offer a way to measure the applied force and response at a point on a light structure. Simultaneous measurement of both of these quantities can provide data on the mechanical mobility and impedance of the structure at the point of interest. These measurements form the starting point of investigations into other dynamic properties such as acceleration, compliance, damping, loss factors and resonance frequencies.

The two impedance heads are identical in construction apart from the method of attaching each to the structure. The Type 8001 has a

tapped 10–32 UNF hole in the base for attaching it to a surface using a stud. The Type 8000 has an untapped base consisting of a finely finished beryllium disc. Both contain the same piezoelectric accelerometer and force gauge in a sealed titanium housing. The accelerometer is a high-sensitivity compression type offering stable and accurate performance over its long working life. The force gauge is also of the highest quality. The outputs of the transducers are fed to individual sockets on the side of each impedance head. Each impedance head comes with an individual calibration chart (see [Fig. 1](#)).

The accelerometer is located above the force gauge. A critical part of the design lies between the force gauge and the base of the impedance head. The force gauge is mounted as close as possible to the driving point, and the stiffness between the two is made extremely high. Thus, the force gauge gives a true indication of the forces transmitted to the point on the structure. The high stiffness of the materials used in the construction ensures that the phase difference between the force and acceleration output signals is less than 1° over a frequency range of 10 kHz.

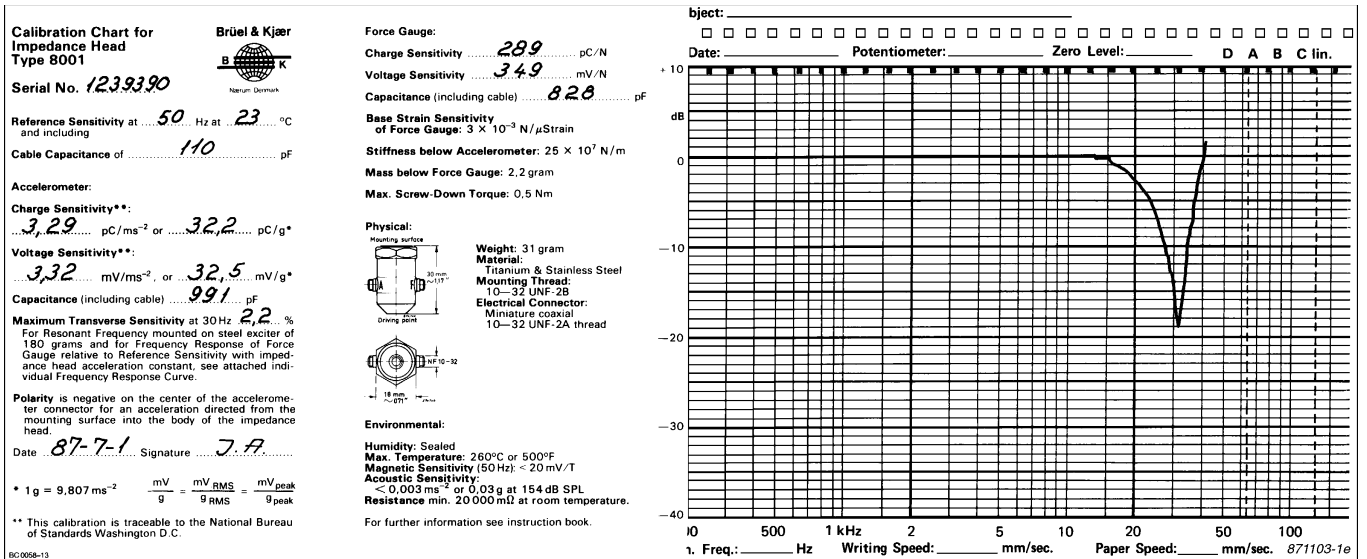

Fig 1 Typical calibration chart for a Type 8001 Impedance Head. The calibration charts accompanying Type 8000 are very similar

Impedance Head Type 8000

With its standardized contact area of 1.75 cm² (0.27 in²), Impedance Head Type 8000 is designed for calibrating the Brüel & Kjær Artificial Mastoid Type 4930 (according to the standards BS4009 (1991), ANSIS3-13 (1987) and IEC 373 (1990)). The impedance head can also be used in measurements on other soft structures and materials.

Impedance Head Type 8001

This is for general purpose measurements on light structures. The structures should have a dynamic mass of less than 1.5 kg (3.31lb) for force measurement errors less than 10%.

Measurements on light structures

For measurements on structures for which the effective dynamic mass is of the same order as the mass below the force gauge in Types 8000 and 8001, the Mass Compensation Unit Type 5565 is recommended. This electrical device corrects the level of the output from the force transducer according to the dynamic mass of the structure.

Measurements on heavy structures

For measurements on masses greater than 1.5 kg (3.31lb), the use of separate force gauges and accelerometers

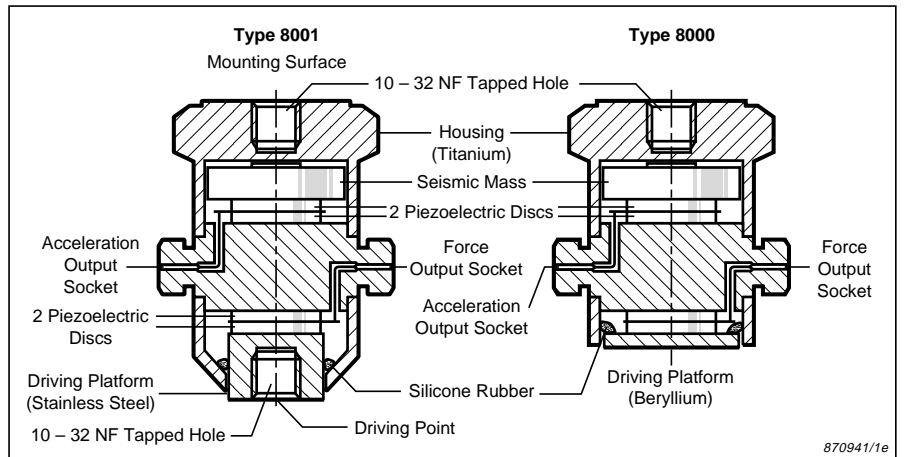

Fig 2 Schematic drawings of Types 8000 and 8001

is recommended. Consult the Brüel & Kjær Sound & Vibration Product Catalogue for details on the appropriate force gauges and accelerometers for your application.

Point-mobility and Point-impedance

Mechanical mobility is defined as the ratio of the velocity of a structure to the force required to produce this ve-

locity. Conversely, the mechanical impedance is defined as the ratio of the exciting force to the resulting velocity.*

From this we define point mobility and impedance with reference to the velocity and force at a single point. This is in contrast to transfer mobility and impedance, which concern the velocity at one point caused by a force acting at another point, and vice-versa.

Mobility and impedance are frequency dependent. The results of a

* The accelerometer in the impedance head produces an acceleration-related output, which does not give the mobility or impedance function directly. Instead, force and acceleration signals give the so-called dynamic mass and its reciprocal, acceleration. If mobility and impedance measurements are required, the acceleration signal must be integrated by the preamplifier. Alternatively, if a dual channel analyzer is used, the mobility or impedance function can be derived via post-processing in the analyzer.

mobility or impedance measurement can be expressed numerically at a given frequency with the appropriate units, or as a plot against frequency. Such a plot represents the mobility or impedance function at that point and is often complex (consisting of real and imaginary parts).

Further analysis of mobility and impedance functions can provide information about damping, loss-factors and natural frequencies of structures and materials.

Using the Impedance Heads

The impedance heads are best used with the Mini-Exciter Type 4810. Typically, the impedance head is attached to the exciter with a small, flexible push rod, which acts like a mechanical fuse and protects the impedance head. The exciter can be suspended above the structure to be tested. In the case of the Type 8000, weakened brass studs (YS0514) are recommended to attach the other end of the impedance head to the structure. These also act like mechanical fuses, eliminating the risk of over-tightening the stud in the impedance head.

An impedance and mobility measurement system can be built around a Dual Channel Signal Analyzer

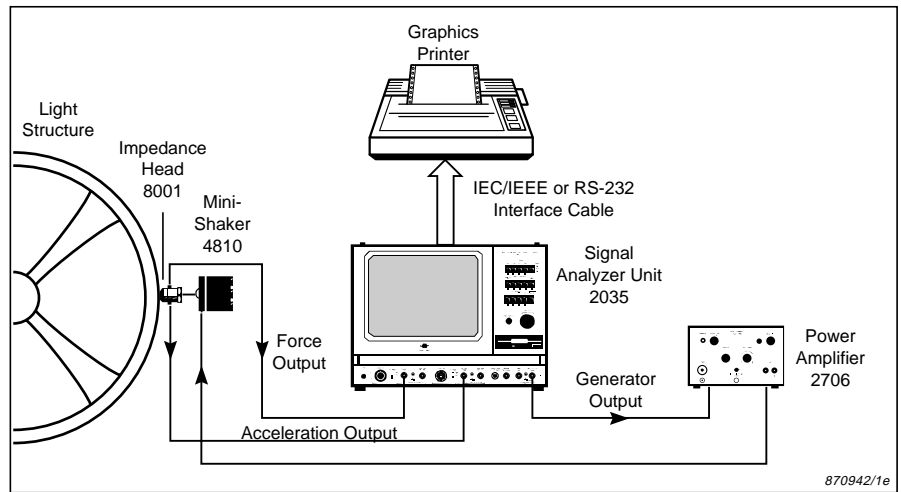

Fig. 3 Set-up for mechanical impedance and mobility measurements

Type 2035 (see Fig. 3). In such a set-up, a random or pseudo-random noise signal is fed from the built-in generator of the Type 2035 into the Power Amplifier Type 2706. The amplified signal is fed into the Type 4810. The measured force and acceleration signals are connected directly to the Acc. Input Charge sockets on the Signal Analyzer Unit Type 2035, which provide conditioning and amplification. The force and acceleration signals are typically connected to Channels A and B, respectively.

The Type 2035 can calculate the complex mobility and impedance functions and display them as magnitude v. frequency, real-part v. frequency, imaginary part v. frequency, phase v. frequency or real v. imaginary (Nyquist plot). Hard copies can be obtained via a printer or plotter. Typical examples of mobility measurements made on a thin plate are shown in Fig. 4.

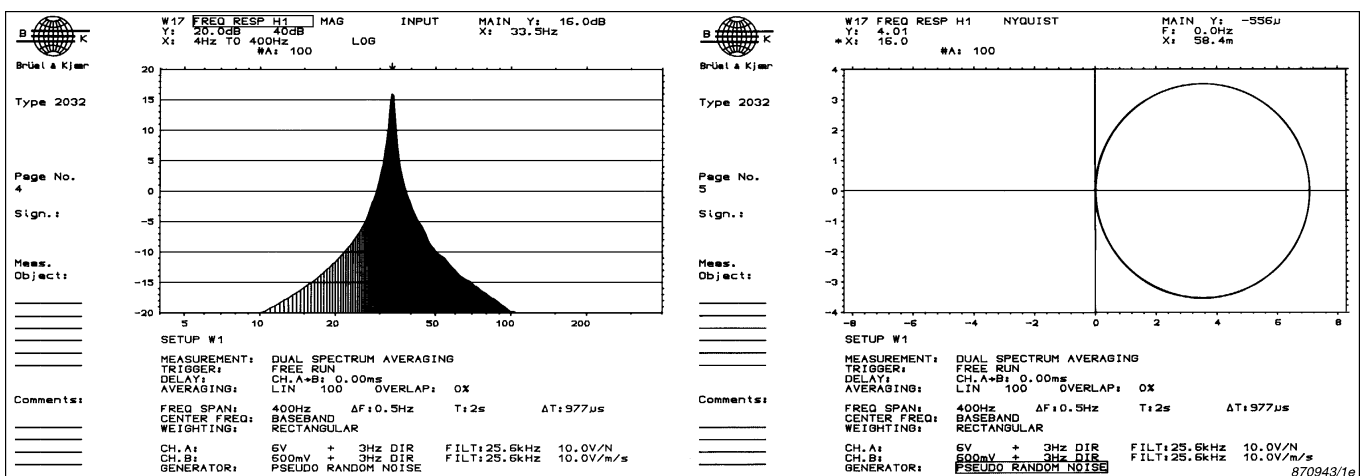

Fig. 4 The mechanical mobility function of a soft rubber material. The function is displayed as magnitude v. frequency (left) and real part v. imaginary part (a Nyquist plot, right)

Specifications 8000 and 8001

Impedance Head Type:	8000	8001
Typical Accelerometer Sensitivity,* individually calibrated within 2%	3pC/ms ⁻² , 3mV/ms ⁻² (30pC/g, 30mV/g) ^Δ	
Typical Force Gauge Sensitivity,* individually calibrated within 2%	370pC/N, (370mV/N)	
Frequency Range* ±5% ±10%	1 – 6000Hz 1 – 10000Hz	
Diameter of surface contacting the test object	15mm (0.59in)	8mm (0.32in)
Mass below force gauge	1.3g	2.1g
Stiffness below accelerometer	25 × 10 ⁷ N/m	
Accelerometer Capacitance* ^{ΔΔ}	1000pF	
Force Gauge Capacitance* ^{ΔΔ}	900pF	
Accuracy of impedance phase angle over specified frequency range (dependent on preamplifier in low frequency range)	±1°	
Impedance measurements with accuracy better than 10% require:	test object dynamic mass ≤ 1.5kg test object contact stiffness ≤ 2.5 × 10 ⁷ N/m	
Force gauge and accelerometer electrical connection	One side connected to base	
Acoustic Sensitivity of accelerometer (dB SPL equivalent to 10ms ⁻²)	184	
Magnetic Sensitivity of accelerometer	<20mV/T	
Transverse Sensitivity of accelerometer*	<3%	
Base Strain Sensitivity of accelerometer with impedance head mounted on mounting surface or on driving point	<5 × 10 ⁻⁴ m/s ² /μ strain (5 × 10 ⁻⁵ g/μ strain) ^Δ	
Base Strain Sensitivity of force gauge with:	impedance head mounted on mounting surface <2 × 10 ⁻⁵ N/μ strain	impedance head mounted on driving point <2 × 10 ⁻⁵ N/μ strain <3 × 10 ⁻³ N/μ strain
Maximum Ambient Temperature	260° C (500° F)	
Leakage Resistance	20000MΩ	
Maximum Shock (typical)	20000m/s ² (2000g) ^Δ	
Maximum Load in tension (static plus dynamic)	300N	
Maximum Load in compression (static plus dynamic)	2000N	
Maximum Screw-down Torque:	of mounting surface of driving point	2.0Nm 0.5Nm
Dynamic Linearity of force gauge for 50N peak	±2%	
Sealing	Silicone Rubber	
Height	28.5mm (1.12in)	32mm (1.26in)
Weight	29g (1oz)	
Material of housing	Titanium	
Material below force gauge	Beryllium	Stainless Steel
Mounting thread	10–32 NF	
Accessories Included		
2 × AO 0038	Low-noise cable, 1.2m (4ft)	
4 × YQ 2962	Threaded steel stud, 10–32 NF	
3 × YO 0534	Mica washer	
2 × YP 0150	Insulated stud, 10–32 NF	
YM 0414	Nut, 10–32 NF	
QA 0029	Screw tap, 10–32 NF	
QA 0013	Allen key, 3/32" for studs	
5 × YS 0514	Weakened stud, 10–32 NF (Type 8001 only)	
	Individual calibration chart	

* Individual values at room temperature are given on the calibration chart Δ g represents the standard gravity unit (not grams) where indicated ΔΔ including standard low-noise cable (1.2m or 4ft)

Brüel&Kjær reserves the right to change specifications and accessories without notice



WORLD HEADQUARTERS:

DK-2850 Naerum · Denmark · Telephone: +45 45 80 05 00 · Fax: +45 45 80 14 05 · Internet: <http://www.bk.dk> · e-mail: info@bk.dk
 Australia (02) 9450-2066 · Austria 00 43-1-865 74 00 · Belgium 016/44 92 25 · Brazil (011) 246-8166 · Canada: (514) 695-8225 · China 10 6841 9625 / 10 6843 7426
 Czech Republic 02-67 021100 · Finland 90-229 3021 · France (01) 69 90 69 00 · Germany 0610 3/908-5 · Holland (0)30 6039994 · Hong Kong 254 8 7486
 Hungary (1) 215 83 05 · Italy (02) 57 60 4141 · Japan 03-3779-8671 · Republic of Korea (02) 3473-0605 · Norway 66 90 4410 · Poland (0-22) 40 93 92 · Portugal (1) 47114 53
 Singapore (65) 275-8816 · Slovak Republic 07-37 6181 · Spain (91) 36810 00 · Sweden (08) 71127 30 · Switzerland 01/94 0 09 09 · Taiwan (02) 713 9303
 United Kingdom and Ireland (0181) 954-236 6 · USA 1 - 800 - 332 - 2040
 Local representatives and service organisations worldwide
 BP 0244 – 14