

Piezoelectric Charge Accelerometer Types 4370 and 4370-V

Uses

- General purpose vibration testing and analysis
- Low-level, low-frequency measurements
- Measurements in high-temperature environments

Features

- High sensitivity
- Low sensitivity to environmental factors



180068

Description

Type 4370 is a DeltaShear™ Unigain* accelerometer. It features a 10–32 UNF-2A top connector and a 10–32 UNF-2B threaded hole for mounting. Type 4370-V† has the same specifications and long-term stability as Type 4370, but it has a relaxed sensitivity tolerance.

Fig. 1 Dimensions of Type 4370

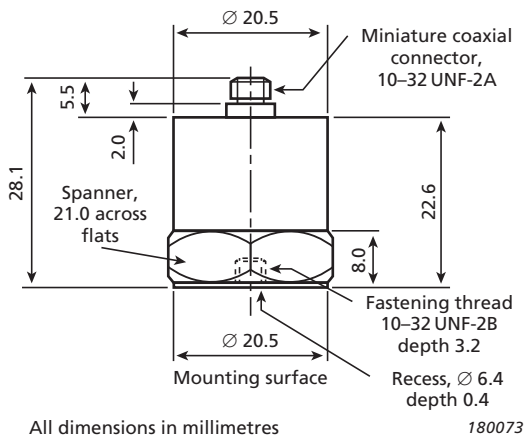

Characteristics

This piezoelectric accelerometer may be treated as a charge source. Its sensitivity is expressed in terms of charge per unit acceleration (pC/ms^{-2} , pC/g).

The DeltaShear design consists of three piezoelectric elements and three seismic masses arranged in a triangular configuration around a triangular centre post. They are held in place by a clamping ring that isolates the configuration from the base. The ring also prestresses the piezoelectric elements to give a high degree of linearity. This design provides a high sensitivity-to-mass ratio, a relatively high resonance frequency and high isolation from base strains and temperature transients.

The piezoelectric element used is a PZ 23 lead zirconate titanate element, and the housing material is stainless steel.

Calibration

The sensitivity is calibrated to a convenient value such as 1, 3.16 or $31.6 \text{ pC}/\text{ms}^{-2}$ for Unigain accelerometers. The sensitivity given in the calibration chart has been measured at 159.2 Hz with 95% confidence level, using the coverage factor $k = 2$.

Fig. 2 Frequency response curves for Type 4370

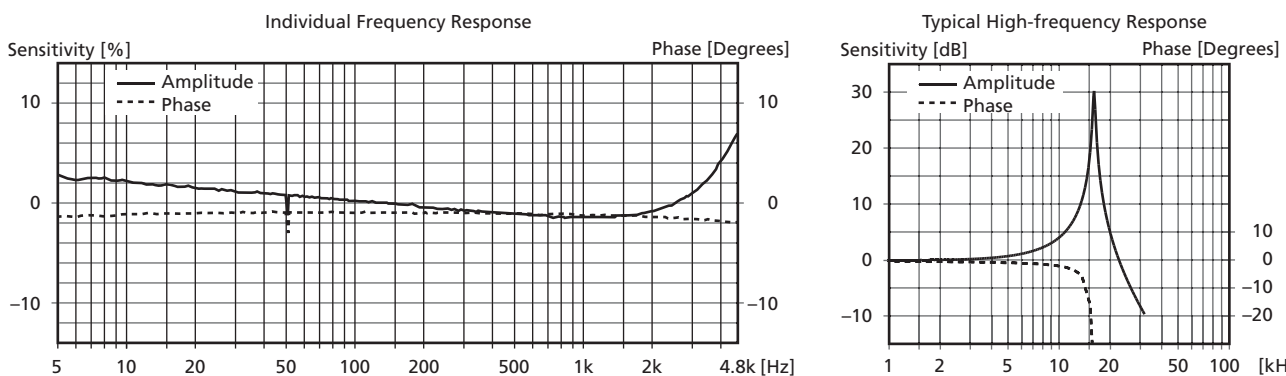

* Unigain: The individual measured sensitivity is within $\pm 2\%$ of the specified sensitivity

† V-type: The individual measured sensitivity is within $\pm 15\%$ of the specified sensitivity

Specifications – Charge Accelerometer Types 4370 and 4370-V

Type No.	4370		4370-V	
General				
Weight	g	54		
	oz	1.9		
Charge Sensitivity (at 159.2 Hz)	pC/ms ⁻²	10 ± 2%	10 ± 15%	
	pC/g	98 ± 2%	98 ± 15%	
Frequency Range (±10% limit)	Hz	0.1 to 4800		
Mounted Resonance Frequency	kHz	16		
Max. Transverse Sensitivity (at 30 Hz, 100 ms ⁻²)	%	4		
Transverse Resonance Frequency	kHz	4		
Max. Operational Continuous Sinusoidal Acceleration (peak)	kms ⁻²	20		
	g	2000		
Electrical				
Residual Noise Level (measured with NEXUS Type 2692-001 in the specified frequency range)	mms ⁻²	0.2		
	mg	0.02		
Capacitance (excluding cable)	pF	1100		
Min. Leakage Resistance (at 20 °C)	GΩ	20		
Environmental				
Operating Temperature Range	°C	-74 to +250		
	°F	-101 to +482		
Temperature Coefficient of Sensitivity	%/°C	0.05*		
Temperature Transient Sensitivity (3 Hz Low. Lim. Freq. (-3 dB, 6 dB/octave))	ms ⁻² /°C	0.02		
	g/°F	0.001		
Base Strain Sensitivity (at 250 µε in the base plane)	ms ⁻² /µε	0.003		
	g/µε	0.0003		
Magnetic Sensitivity (50 Hz, 0.038 T)	ms ⁻² /T	1		
	g/kG	0.01		
Max. Non-destructive Shock (± peak)	kms ⁻²	20		
	g	2000		
Mechanical				
Housing Material	Stainless Steel, AISI 316			
Piezoelectric Sensing Element	PZ 23			
Construction	DeltaShear			
Sealing	Welded			
Electrical Connector	10–32 UNF-2A			
Mounting	10–32 UNF-2B × 3.2 mm threaded hole			
Mounting Torque	Max.	Nm (lbf-in)	3.5 (31)	
	Min.		0.5 (4.4)	

* In the temperature range -25 to +125 °C (-13 to +257 °F)

All values are typical at 25 °C (77 °F) unless measurement uncertainty is specified

COMPLIANCE WITH STANDARDS



Brüel & Kjær and all other trademarks, service marks, trade names, logos and product names are the property of Brüel & Kjær or a third-party company.

Ordering Information

Type 4370

includes the following accessories:

- Carrying box
- Calibration chart
- AO-0038: Low-noise coaxial cable, 10–32 UNF, length 1.2 m
- 10–32 UNF threaded steel stud, length 12.7 mm

Type 4370-V

includes the following accessories:

- Carrying box
- Calibration chart
- 10–32 UNF threaded steel stud, length 12.7 mm

Optional Accessories	
AO-0038-x-yyy*	Low-noise coaxial cable, 10–32 UNF connectors, 250 °C (482 °F)
AO-0122-x-yyy*	Super low-noise cable, 10–32 UNF connectors, 250 °C (482 °F)
AO-0231-x-yyy*	Super low-noise cable, 10–32 UNF to TNC, 180 °C (356 °F)
AO-1382-x-yyy*	Flexible double-screened coaxial cable, 10–32 UNF connectors, 250 °C (482 °F)
DB-0544	Probe with round tip, 10–32 UNF
JJ-0207	Plug adaptor, 10–32 UNF to TNC (female)
JP-0162	Plug adaptor, 10–32 UNF to TNC (male)
QA-0013	Hexagonal key for 10–32 UNF studs
QA-0029	Tap for 10–32 UNF thread
UA-0078	Accelerometer accessory set
UA-0553	Mechanical filter (set of five)
UA-0641	Extension connector, 10–32 UNF to TNC
UA-0642	Mounting magnet and two insulating discs
UA-0866	Cementing stud, 10–32 UNF, dia. 14 mm (set of 25)
YG-0150	Steel stud, double-ended with flange, 10–32 UNF, length 5.3 mm
YJ-0216	Beeswax for mounting
YP-0080	Probe with sharp tip, 10–32 UNF
YP-0150	Insulated stud, fully threaded, 10–32 UNF, length 13 mm
YQ-2960	Set screw, 10–32 UNF × 1/2" (12.8 mm)
YQ-2962	Set screw, 10–32 UNF × 5/16" (7.7 mm)
Type 4294	Calibration Exciter
Calibration Services	
ACC-M-CAI	Accredited initial calibration
ACC-M-CAF	Accredited calibration
ACC-M-CFF	Factory standard calibration
ACC-M-CTF	Traceable calibration

* x = D (decimetres) or M (metres)
 yyy = length in decimetres or metres
 Please specify cable length when ordering

Brüel & Kjær Sound & Vibration Measurement A/S
 DK-2850 Nærum · Denmark · Telephone: +45 77 41 20 00 · Fax: +45 45 80 14 05
 www.bksv.com · info@bksv.com
 Local representatives and service organizations worldwide

Although reasonable care has been taken to ensure the information in this document is accurate, nothing herein can be construed to imply representation or warranty as to its accuracy, currency or completeness, nor is it intended to form the basis of any contract. Content is subject to change without notice – contact Brüel & Kjær for the latest version of this document.

Brüel & Kjær

