

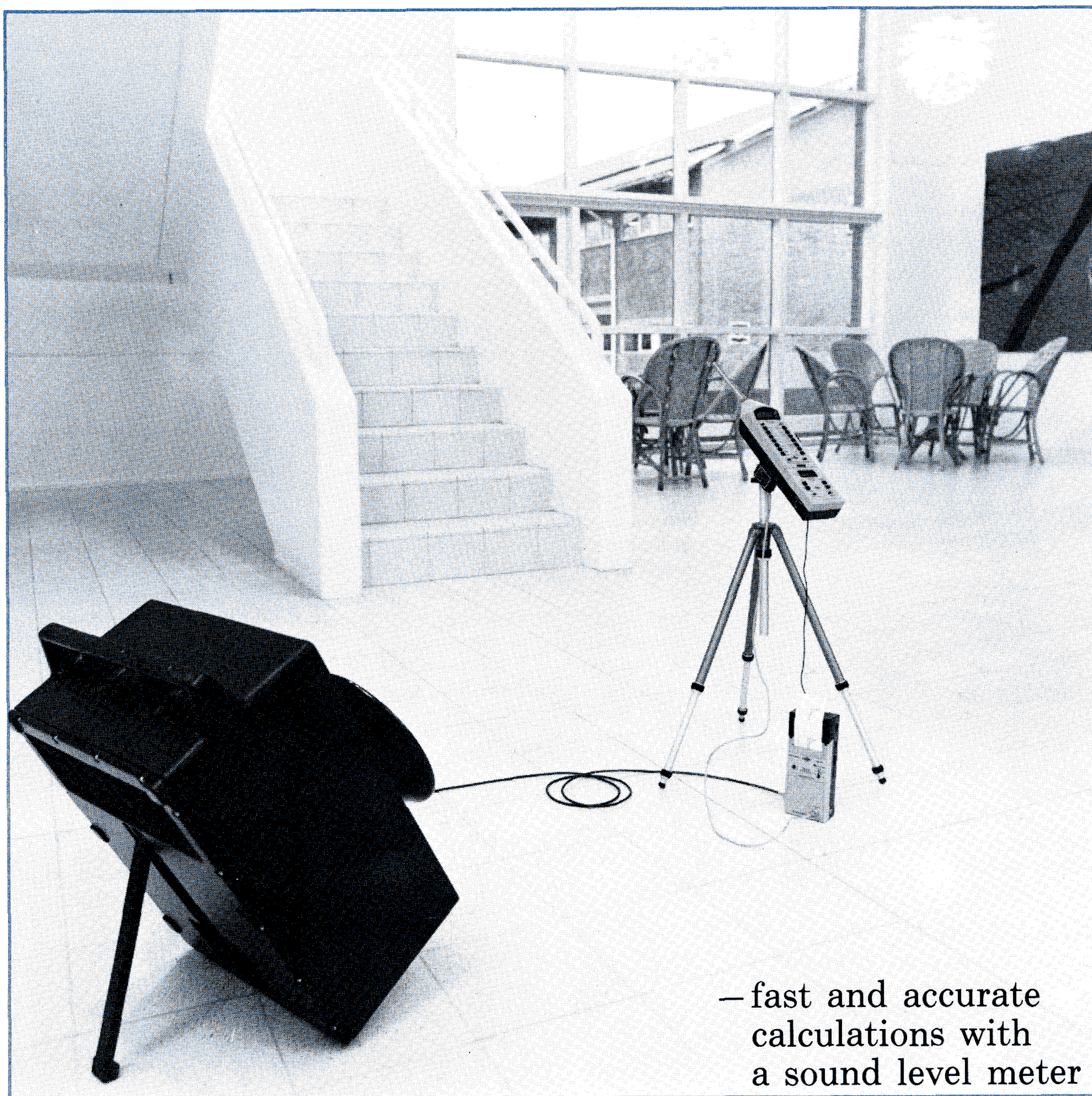

Reverberation Time



Introduction

A sound level meter equipped with software to calculate reverberation time has opened the way for quick measurements and presentable results. With an altogether more simple, as well as totally professional, measurement system, the making of reverberation measurements has never before been such an attractive proposition.

This Application Note demonstrates how easy it is to make accurate reverberation measurements and it is hoped that it sheds extra light on the use of noise-bursts as opposed to the more familiar 'cut-off noise' method.

Location

A school was chosen for demonstration measurements because of the variety of rooms available. These included classrooms with both long and short reverberation times, a gymnasium and a large sports hall.

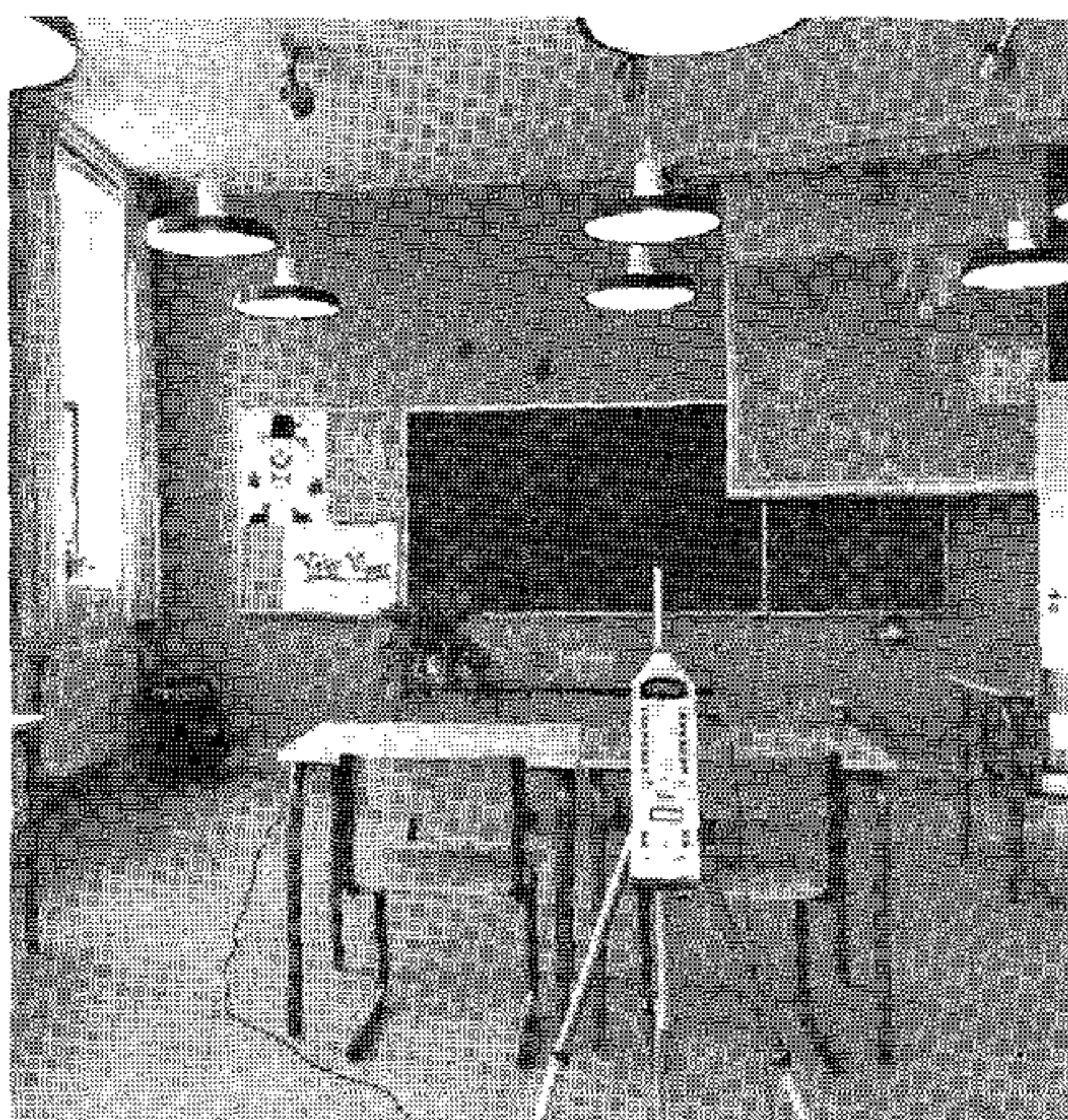

Fig. 1. Classroom 1

Measurements

Equipment:

Sound Level Meter	Type 2231
Reverberation Processor	BZ 7104
$1/3$ - $1/1$ Octave Filter Set	Type 1625
Sound Source	Type 4224
Interface Module	ZI 9100
Graphics Printer	Type 2318

Classroom 1 (164 m³)

A quick survey of the room revealed that it was box-shaped with plaster walls, plaster-board ceiling and linoleum-finished floor. It had one door and four large windows (with fully drawn-back curtains). Fittings included fourteen wooden classroom tables and chairs and a 4 m² pin-board.

Six well-spaced points were marked on the floor and numbered. The distribution of these points is shown in Fig. 2 together with the measurement system. The sound source was placed in a corner and the sound level meter was positioned so that its microphone was 1 m above point 1.

The sound level meter, loaded with Reverberation Processor Module BZ 7104, was set up to make $1/3$ -octave band measurements in the frequency range 125 Hz to 4 kHz. The 'count-down-to-start' feature gave the operator time to leave the room and close the door. An automatic sequence of noise-bursts in successive $1/3$ -octave bands was then generated by the sound level meter and transmitted into the room by the sound source.

Results from the sixteen frequency bands were available after approximately two and a half minutes. These were printed out to help check for errors, warnings or irregularities. Background-noise warnings were noted in some of the higher frequency bands and so measurements in these bands were repeated. The warnings were not reproducible and were therefore attributed to noise 'events' that occurred during the measurements rather than constant background noise. A new printout was made that included the repeated results.

The whole automatic measurement sequence was repeated at each of the five remaining positions with microphone elevations of between 1 and 2 m. Only one set of measurements was made at each position since the measurement method produces results that vary by typically less than 2% at one point, i.e. much less than from

position to position. The 'classroom 1' curve in Fig. 3 shows the 'spatially' averaged results for the six microphone positions.

To test the effects of the amplifier and loudspeaker on measurement results, the experiment was repeated for three microphone positions with Brüel & Kjær Sound Power Source Type 4205 in place of the Type 4224. These results are also shown on the 'classroom 1' curve in Fig. 3.

Classroom 2 (200 m³)

The second classroom visited possessed absorptive materials as an integral part of the ceiling construction. Otherwise the room description was quite similar to that of classroom 1. Reverberation measurements were again made at six different positions and the spatially averaged results are shown in Fig. 3. Also shown on the 'classroom 2' curve are the results obtained by spatially averaging over only three microphone positions.

Gymnasium (950 m³)

This relatively small gymnasium had a floor of the sprung wooden type commonly used in sports facilities and walls of rough brick. The windows were set high-up in the walls and the plastic curtains were drawn back during measurements. A wooden-slat ceiling sloped gently up to a centre beam running the length of the room.

Again, six measurement positions were used and the spatially averaged results are shown on the 'gymnasium' curve in Fig. 3. As an investigation into the influence of sound source position on measurement results, further measurements were made with the sound source moved into the opposite

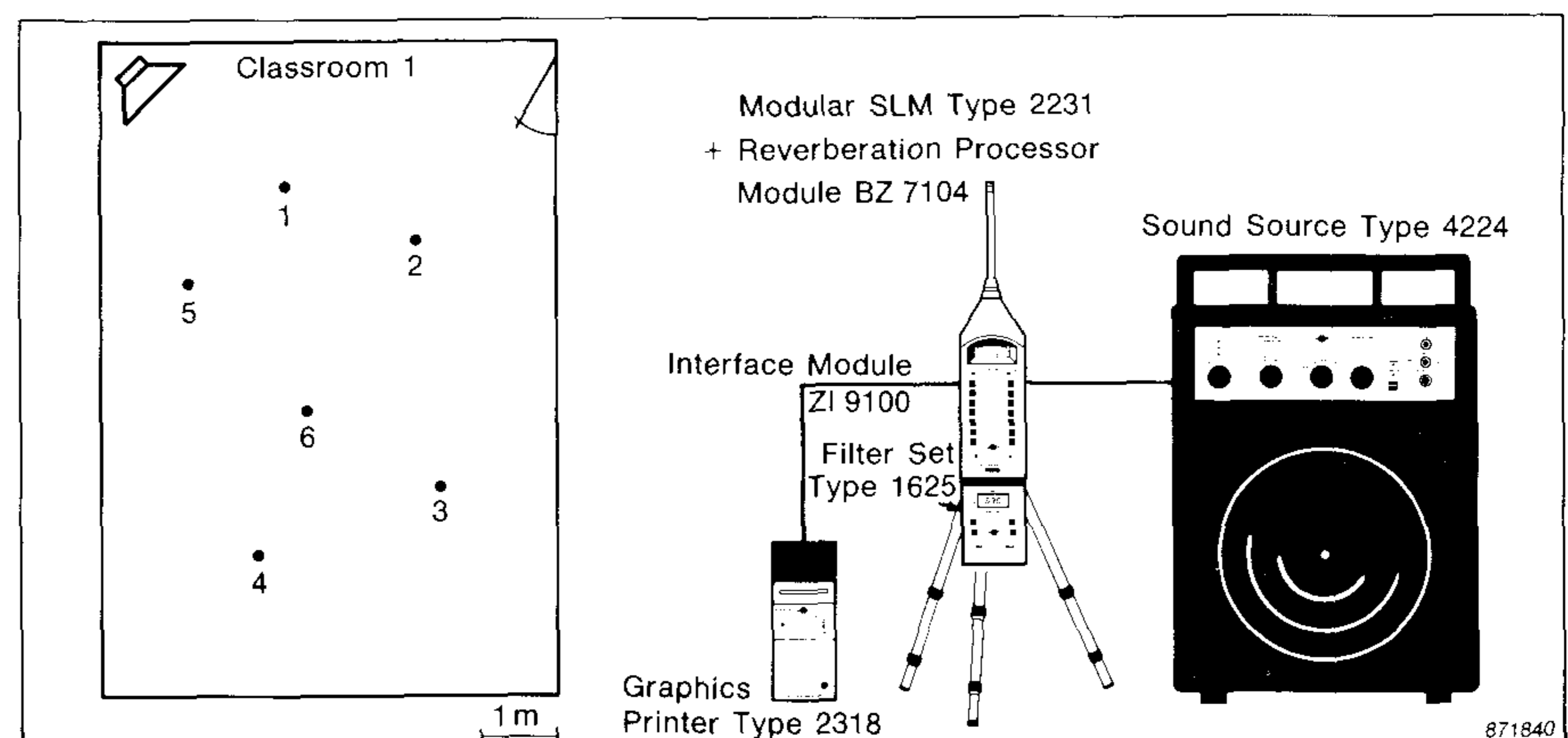

Fig. 2. Measurement points in classroom 1 and the measurement system

corner of the room. These additional results are also shown in Fig. 3.

Sports Hall (3750 m³)

The purpose of this large hall was primarily for indoor soccer. It was therefore a simple box-shaped enclosure with a hard floor, walls of painted brickwork and virtually no reflecting surfaces other than the smooth hall boundaries. Doors into the arena were metal, and sheet-metal protective covers were in place over the observation windows. There were mineral wool slabs suspended between the support beams of the flat roof. Measurements were made at six positions in the hall and the spatially averaged results are shown in the 'sports hall' curve in Fig. 3. Also shown are the spatially averaged results from three measurement positions.

Discussion of results

Classroom 1

This classroom had 'live' ambience which was immediately apparent on entering the room. The 'classroom 1' results curve in Fig. 3 shows why — the reverberation times are greater than 1s at practically all frequencies of interest.

Also shown on the 'classroom 1' curve are the closeness of results obtained by using two different sets of amplifier and loudspeaker. The maximum difference between results was 0,05s across the whole frequency range. This was very close, particularly as the 'Type 4205' results were only

obtained by using three measurement positions, for the sake of quickness.

Classroom 2

The presence of more sound-absorbing material, particularly on the ceiling, accounted for the reverberation times of this room being approximately half that of classroom 1. The 'classroom 2' curve in Fig. 3 shows that the results obtained by spatially averaging over a reduced number of three measurement positions were within $\pm 5\%$ of the spatial average over six positions ($\pm 10\%$ below 160 Hz), even though there was a lot of damping in the room.

Gymnasium

The 'gymnasium' results-curve in Fig. 3 features the closeness of the results obtained with the Type 4224 sound source first in one corner of the room, and then in the opposite corner. A typical example of a printout from the Type 2318 printer is shown in Fig. 4.

Sports hall

A challenge to the BZ 7104 method of measuring reverberation time was presented by the acoustics of the large sports hall which had a notable lack of reflecting surfaces and hence minimal 'diffuseness'. However, results were consistently measurable, even with the hall's ventilation system operating during the measurements.

Once again, results obtained by averaging over only three measurement positions were within $\pm 5\%$ of the spatial average over six measurement positions ($\pm 10\%$ below 160 Hz).

Measurements in larger enclosures than the sports hall present no difficulties — provided that there is adequate sound power output from the sound source and reasonable diffuseness in the enclosure. For these sports hall measurements, advantage was taken of the high sound power output level of the Type 4224 sound source (115dB re 1pW in the frequency range 100Hz to 4kHz, when battery operated).

Freq. [Hz]	T(30) [Sec]	T(20) [Sec]	EDT [Sec]
125	1.05	1.10	0.91
160	1.28	1.51	0.85
200	1.56	1.66	1.51
250	1.59	1.65	2.15
315	2.25	2.20	2.11
400	2.34	2.21	2.20
500	2.21	2.28	2.25
630	2.15	2.13	2.11
800	2.24	2.20	2.04
1000	2.27	2.32	2.32
1250	2.39	2.33	2.34
1600	2.47	2.41	2.36
2000	2.43	2.37	2.29
2500	2.29	2.25	2.22
3150	2.06	2.02	2.03
4000	1.96	1.93	1.90

872075

Fig. 4. Printout of results from one position in the gymnasium

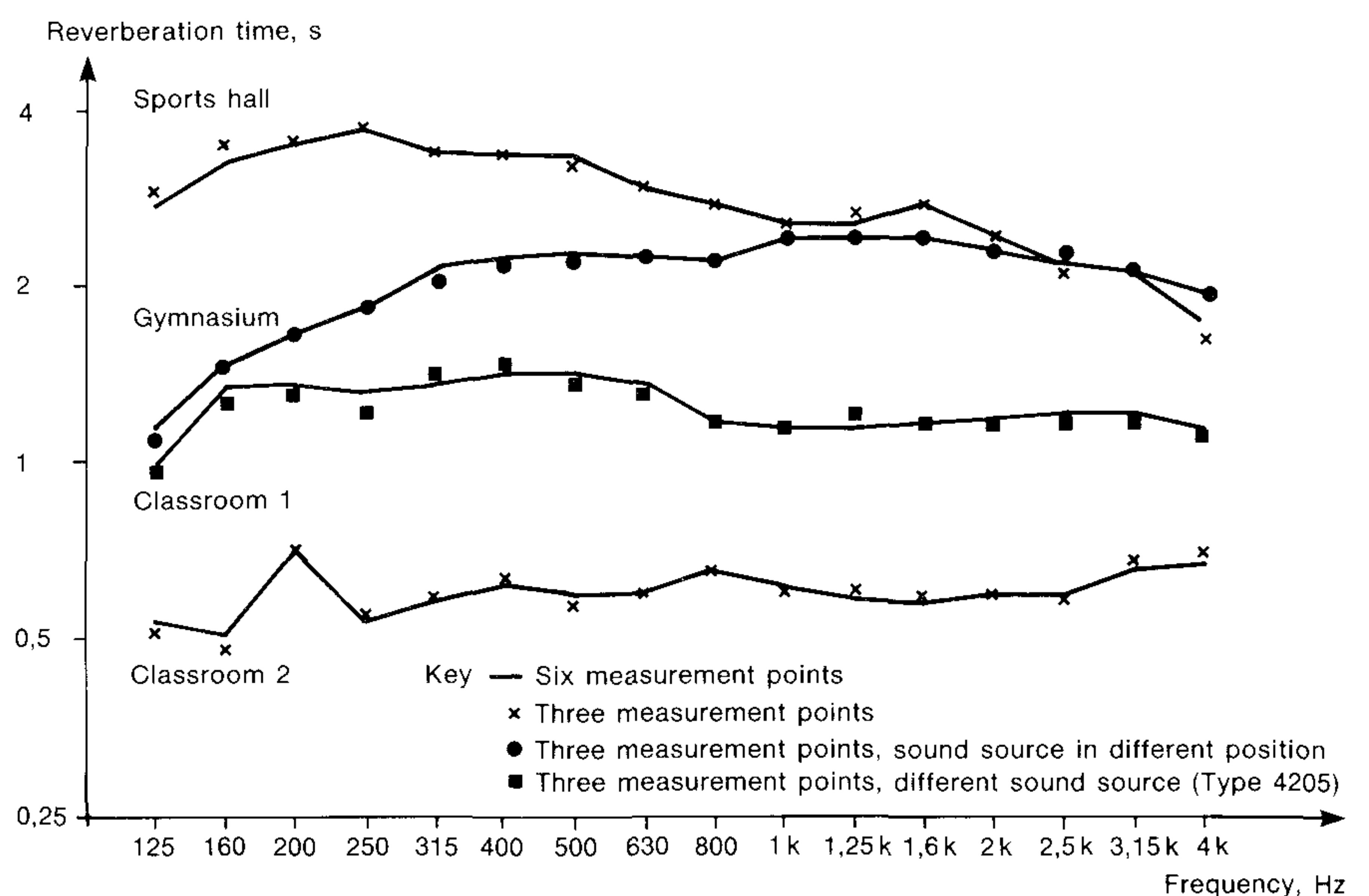

871839

Fig. 3. Spatially averaged $T_{,(20)}$ reverberation time results

Conclusions

Measurements were very quick and easy to make. This allowed much more experimentation than was originally planned. For example, investigations were made into the effect of sound sources, sound-source positions and number of measurement points on the final results.

It was seen that 'quick' measurements at only three measurement positions produced results within $\pm 5\%$ of the spatial averages over six positions in all the rooms ($\pm 10\%$ below 160 Hz). This suggested that the choice of six measurement positions was quite adequate and that three positions would often be acceptable.

Potential applications of such a portable, battery-operated measurement system include: quick measurement of Early Decay Time, checking that rooms conform with regulations, determining sound insulation, or doing consulting work in places that have unsatisfactory acoustic comfort.

Reverberation Processor Module BZ 7104 — Some Questions Answered

What does BZ 7104 do?

BZ 7104 calculates a reverberation decay and three reverberation time results from the impulse response of an enclosure to a limited-bandwidth noise-burst.

Where does the noise-burst come from?

The noise-burst originates in BZ 7104 memory. Here, two different waveforms are stored, one for $1/3$ -octave and the other for $1/1$ -octave measurements. The transmission speed of the chosen waveform is controlled by the processor to allow its use in different frequency bands. A summary of the complete measuring process is given in Fig. 5.

How are impulse responses and reverberation decays related?

A 'squared and reverse-integrated' impulse response is equivalent to the ensemble average of an infinite number of squared reverberation decays.

What does 'reverse-integration' mean?

It means that integration is done in the reverse-time direction. By integrating this way the calculated decay has a characteristic flat top which acts as the 0dB reference line. See Fig. 6.

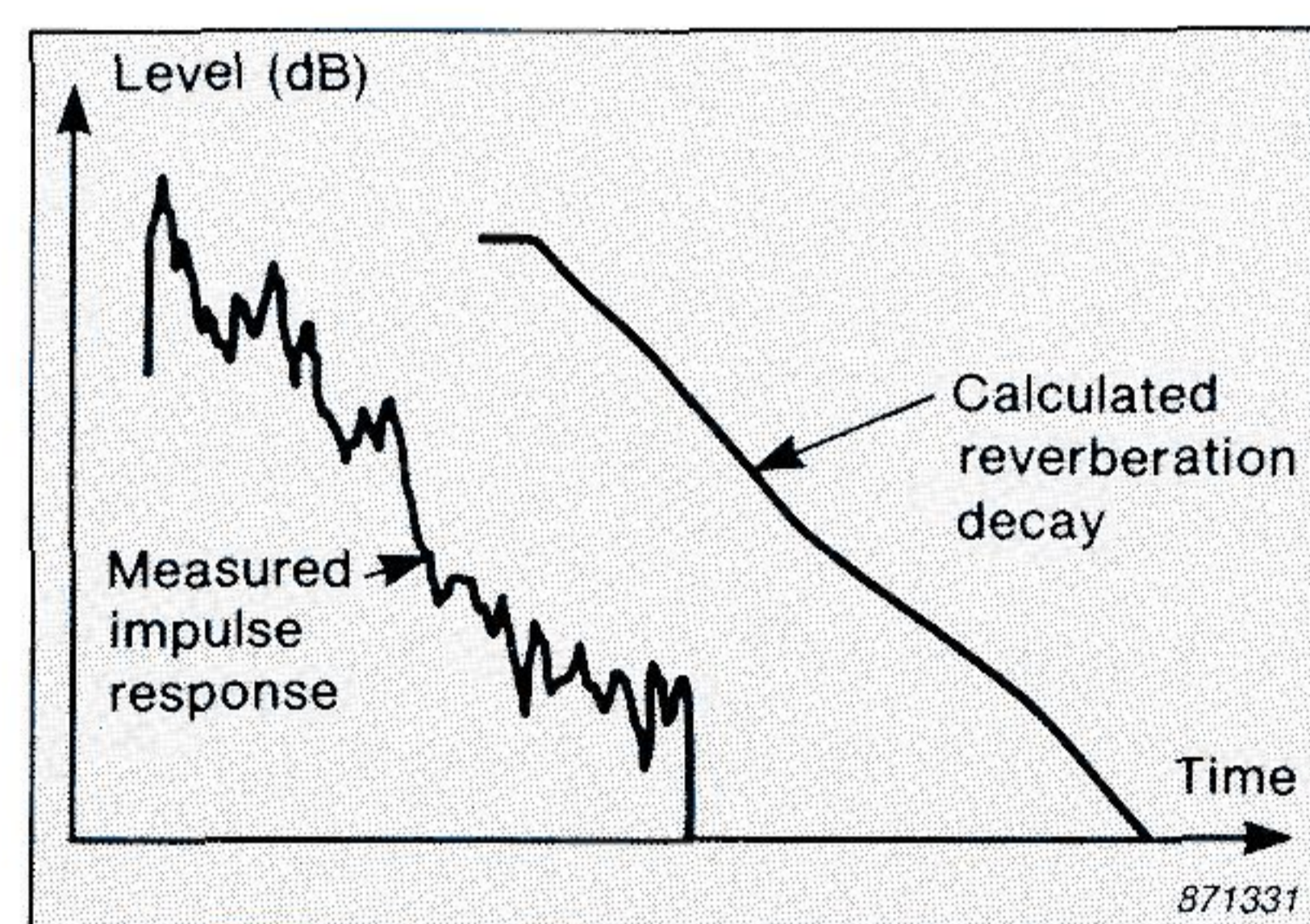

Fig. 6. A typical enclosure impulse response and the reverberation decay calculated from it

Why are three different reverberation time results calculated?

Standardized methods recommend that reverberation time results are obtained by extrapolating a 30 dB segment of measured reverberation decay to 60 dB. However, in many practical situ-

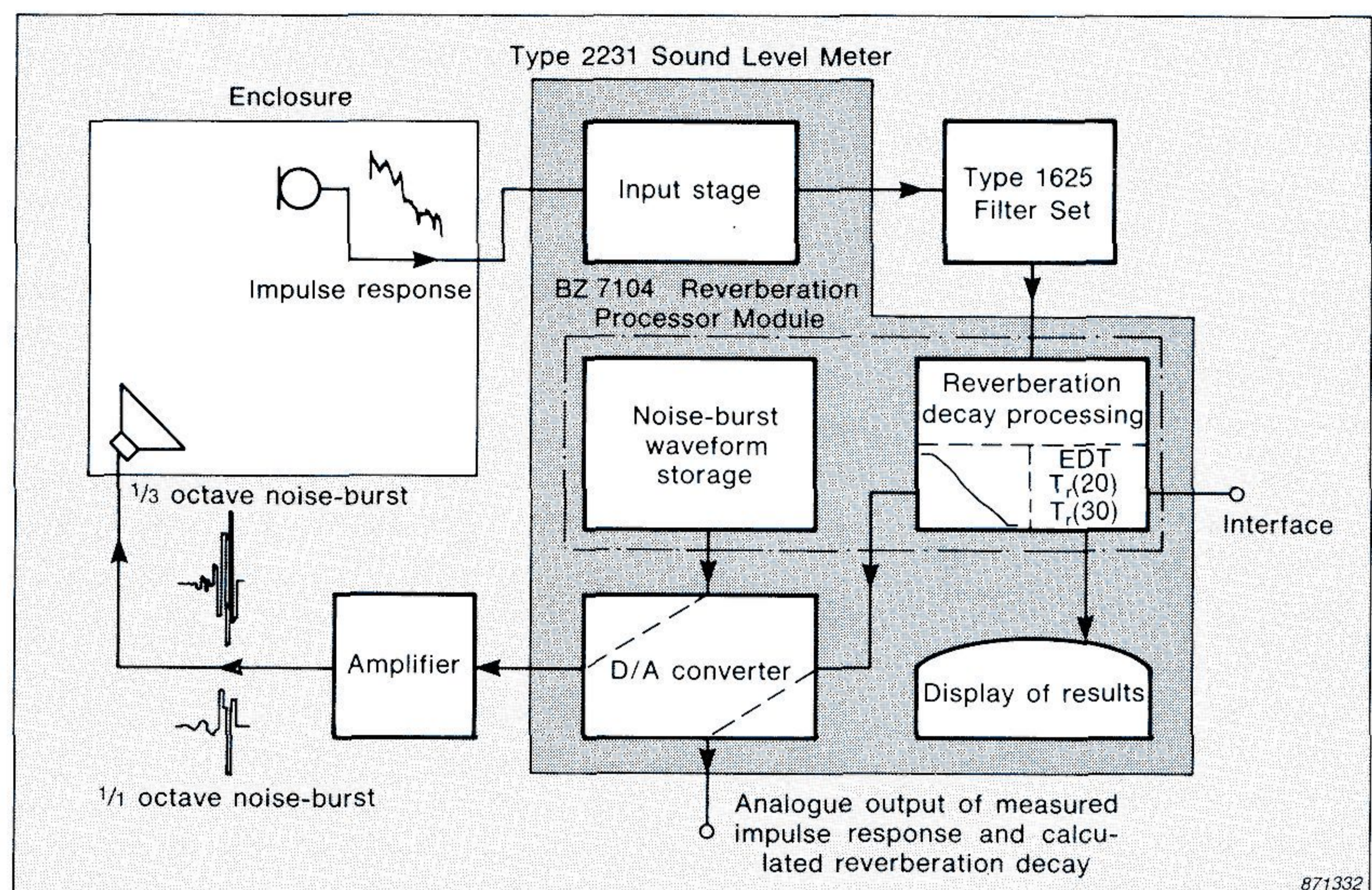

Fig. 5. Diagram showing how the noise-bursts are transmitted into the enclosure and processed to give reverberation results

ations the full 30 dB decay is difficult to measure, so $T(20)$ is a commonly used alternative. Early Decay Time (EDT), which describes the initial decay rate in the enclosure, is calculated because it has proved to be important in describing the subjective reverberation properties of a room.

What exactly are $T(30)$, $T(20)$ and EDT?

They are the estimated times for 60 dB decays based on the behaviour of the calculated reverberation decay in the ranges 0 dB to -10 dB (EDT), -5 dB to -25 dB ($T(20)$) and -5 dB to -35 dB ($T(30)$). BZ 7104 calculates these quantities by extrapolating best-fit straight lines. See, for example, the calculation of EDT in Fig. 7.

What are the advantages of this method over the more familiar methods?

Greater speed, accuracy and flexibility. Another advantage is that the calculated reverberation curve is continuously downward-sloping, unlike the wildly fluctuating reverberation decays measured by the 'cut-off method'. This makes for better interpretation of results — particularly the initial part of the reverberation decay which contains the EDT information.

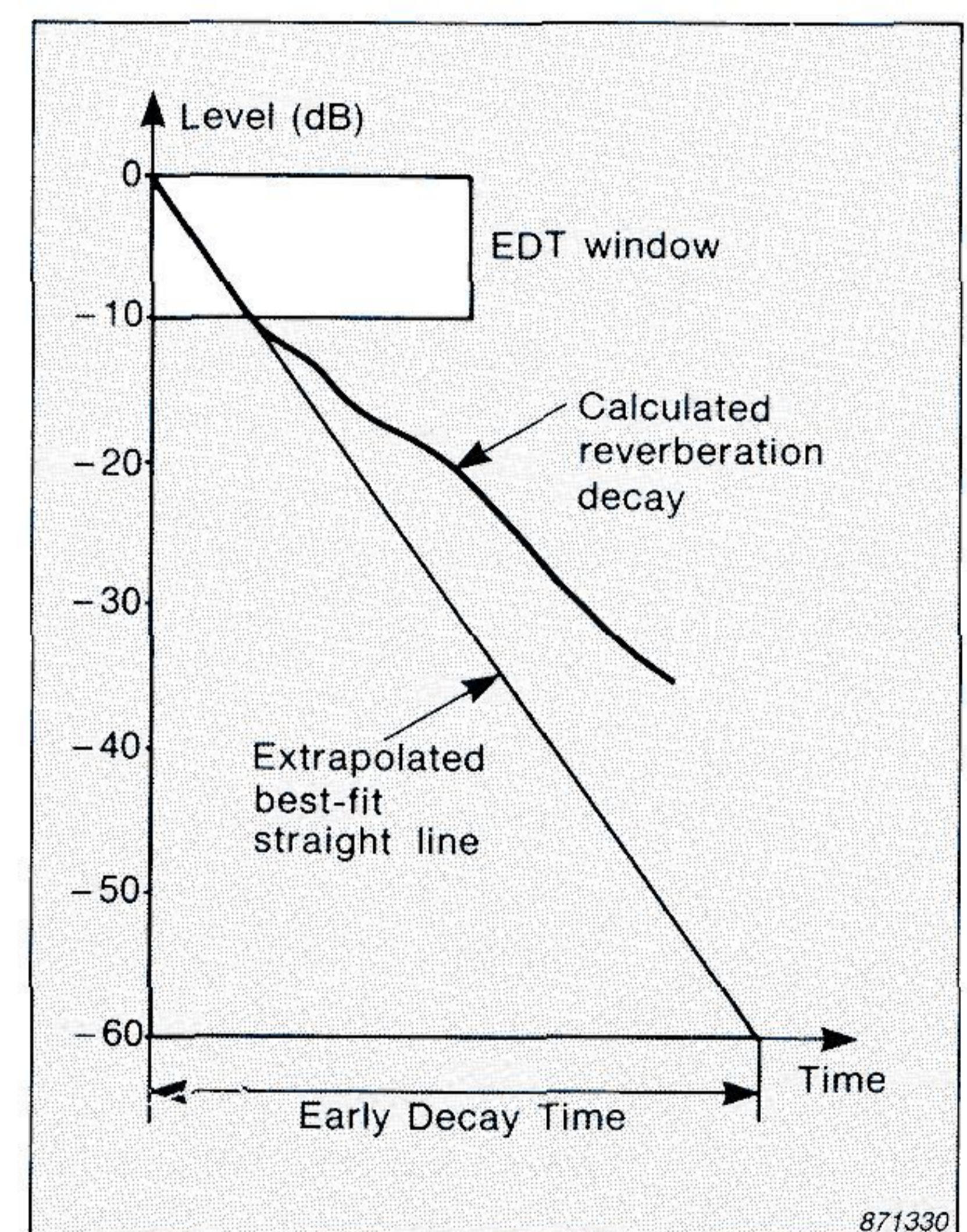

Fig. 7. Example showing how EDT is calculated

M.R. Schroeder sums up the convenience of the method in his paper entitled "New Method of Measuring Reverberation Time" (J. Acoust. Soc. Am. 37. 409-412 (1965)): "A single measurement yields a (calculated) decay curve that is identical to the average over infinitely many decay curves that would be obtained from exciting the enclosure with bandpass-filtered noise."

Brüel & Kjær 

WORLD HEADQUARTERS: DK-2850 Nærum · Denmark · Telephone: +45 2800500 · Telex: 37316 bruka dk

Australia (02) 450-2066 · Austria 02235/7550*0 · Belgium 02-242-9745 · Brazil 2468149 · Canada (514) 695-8225 · Finland (90) 8017044 · France (1) 64572010
 Federal Republic of Germany (04106) 4055 · Great Britain (01) 954-2366 · Holland 03402-39994 · Hong Kong 5-487486 · Italy (02) 5244141
 Japan 03-435-4813 · Republic of Korea 02-793-6886 · Norway 02-787096 · Singapore 2258533 · Spain (91) 2681000 · Sweden (08) 7112730 · Switzerland (042) 651161
 Taiwan (02) 7139303 · USA (617) 481-7000 · Local representatives and service organisations world-wide